

S-Force – air performance with the  
power of world champions



The new high-performance  
compact fans

The engineer's choice

**ebmpapst**

# Our favorite job: redefining what is technically possible.

## **To talk fans is to talk ebm-papst**

It is surely no coincidence that the S-Force series comes from us. For decades, ebm-papst fans have set the standards when it comes to cooling all kinds of electronic components extremely quickly, powerfully and efficiently. Whether they are needed for cooling server rooms or switch cabinets, complex machines or sensitive medical technology – our intelligent and controllable high-performance fans can be adapted to any cooling situation. Our knowledge of the industry allows us to develop highly specialized solutions. The models of the S-Force series all have one thing in common: they are the most powerful compact fans in the world in their class.

## **Innovative leaders, pioneers, trendsetters**

The global market has given us lots of names. That may be due to the fact that there is nothing on earth that motivates our development and design engineers more than quiet and intelligent airflow. To this end, they research and work every day on innovative technologies and new ideas, examining practical requirements and listening to what our customers want. The compact housing of every one of our fans holds the inventiveness and know-how of our employees gathered over decades. For investments in research and development are more than a mere matter of course. They are the foundations on which our success is built.



*Innovations are advancing the world of IT and electronics at an unimaginable pace. Here, fast processors and complex applications also demand ever greater performance from cooling and fan systems. At ebm-papst we see ourselves as a technological trend-setter and we exploit our world-famous pioneering spirit. For it is precisely this that incites us every day to work on excellent innovations that redefine the benchmark of what is possible. Even if that means that we have to exceed ourselves, like with the S-Force series.*



### **Three strengths, one idea**

Motor technology, fluid mechanics and electronics – these core competencies have always been our characteristics. They form the basis for every technical milestone from our company, including the S-Force series. From the finest detail in the mechanics of the housing to the use of electronically commutated motors, we have scrutinized every component until the best performance possible was achieved. For only if all aerodynamic factors work together in perfect synthesis can the best possible performance, which you are entitled to expect from our products, be realized – and that is what you will find with the S-Force.

# Our contribution to noise control: we stir up a storm about aerodynamics.

*A special feature of the continual ground-breaking engineering performance of ebm-papst is the wealth of superior aerodynamic details that characterise every one of our fans. Because our engineers understand exactly how airflow behaves in every phase of its movement, they are able to develop special aerodynamic concepts for our compact fans. To boost air performance and pressure build-up.*

## **The art of understanding air**

If you want to move air intelligently, efficiently and quietly, you have to work with it. It is not enough to simply force the air to do what you want. It doesn't matter whether need to move an object such as an airplane as quickly and as quietly as possible through air as a medium or the other way around – move the air through a stationary fan: in both cases, the aerodynamically optimized design of the body makes sure that the motion flows smoothly.

Here, we can make full use of our expertise in the field of aerodynamic interrelationships. Using state-of-the-art computer programs and realistic flow simulations, the profiles of the fan blades and the inner contours of the S-Force housing have been optimized – precisely matched to the size, the air performance and motor output available. Complex analyses and measurements in an ultramodern acoustic measuring chamber accompany every series of fans from the very beginning.



**Minimum noise**

In particular in the field of IT, where technology is used to support people and not to burden them, minimum noise development is a priceless asset for device cooling. From the minimum possible spacing between the impeller and the fan housing to the use of winglets on the tips of the blades, not unlike the ones we see on aeroplanes – the aerodynamically optimal design, coupled with maximum mechanical precision, allows the S-Force fans to run with constantly low noise relative to air performance, even at their optimum operating point.

**Maximum aerodynamic efficiency**

Naturally, the aerodynamic refinement of the components is not only used to reduce noise – after all we are talking about high-performance fans. Our engineers have developed a series of special impellers for the new product range, whose revolutionary fan wheel design provides for an unrivalled pressure build-up. The especially steep curves of this fan generation display values that are close to the limits of what is possible using radial designs. The perfect aerodynamics contributes this product range rightly being referred to as the best on the market.



# Powerful performance alone is not everything. But it is certainly something!

*Pay nothing and you get nothing – even today, this old saying has lost nothing of its poignancy. For this reason, the powerful cooling capacity of the S-Force generation starts with an extra-powerful drive. Economical and intelligent motors with ebm-papst DC technology are of course first choice here. For maximum cooling capacity in every class and size of fan, with minimum noise and minimum energy consumption.*

## **Powerpacks at the start**

If a fan series is to produce the highest air flow and highest pressure of all the fans on the market of the same size, or put another way, if maximum cooling capacity is needed without compromise, then you shouldn't save on motor output. The very heart of our modern fans are thus the ultra-compact direct current motors with wear-free electronic motor commutation. The DC motors convince not only with their very high efficiency of up to 89 %, they are also highly effective and flexible and also extremely powerful.

## **Full throttle with multipole motors**

Every S-Force fan packages more than 60 years of ebm-papst expertise in the field of drive technology. For the first time, we have a series of high-performance fans equipped with newly-developed, 3-phase motors with 9-groove stator. The combination with high-remanence magnets marks a significant optimization of the magnetic circuit. This allows these new TURBODRIVE motors from ebm-papst to achieve an impressive peak output of 320 watts – that is an increase of 500 percent compared to the direct predecessor of the same size.

*Calculation of airflow within the motor. Computer simulation is used to visualize the cooling air flow for sensitive operating points.*

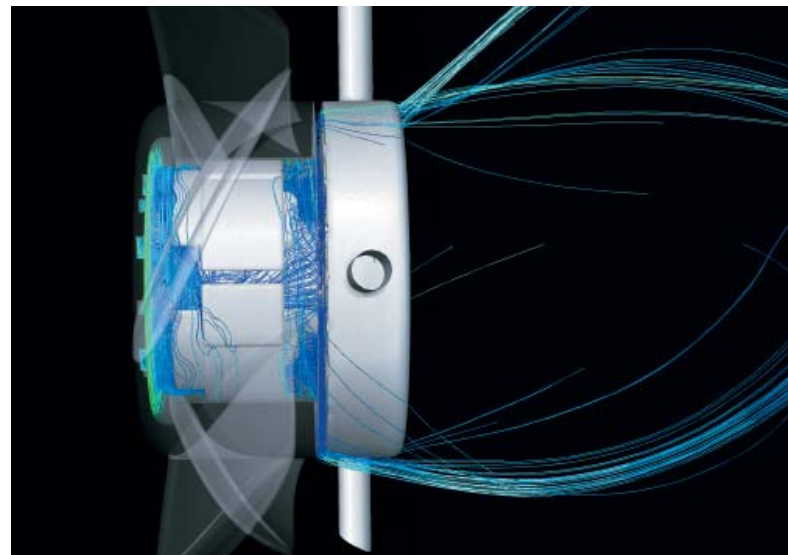
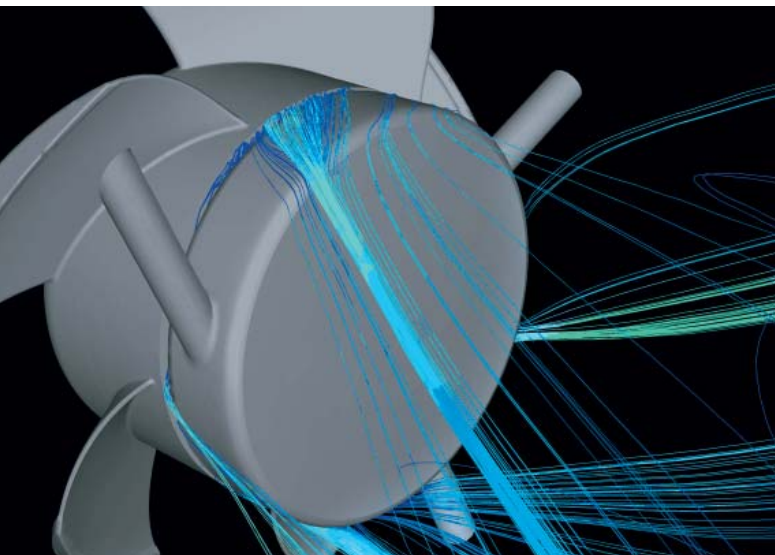

### **A cool head at maximum output**

Extremely high speeds always make electric motors more prone to wear. ebm-papst high-performance fans counter this effect extremely effectively with systematic self-cooling at critical operating points. Simulation methods specially developed for this purpose allow motor cooling to be defined right at the start of development for all operating points. That makes it possible to precisely optimize the airflow within the motor needed for cooling right down to the finest detail – for minimal operating temperatures at all motor components and for maximum service life expectancy.

### **Smooth running and multifunctional**

Newly-developed commutation techniques allow a gently reversal of polarity and minimum switching losses, contributing to the exceptionally smooth running even at high speeds. By avoiding steep switching edges when changing motor coil, the structure-born noise induced by the motor is significantly reduced. With intelligent features such as speed monitoring, closed loop speed control, operation monitoring, TURBODRIVE drives or microprocessor-controlled motor management for software-based fan operation, the electronically commutated compact fans can be perfectly adapted to individual requirements.



# Uncompromising precision.

*The benefits of a compact size without compromising on air performance and pressure build-up? Only ebm-papst can manage that. The new compact fans achieve impressive air flow and pressure figures, which until now have been the reserve of fans with much larger dimensions. Packaging so much power into such a small space demands the development of a particularly robust housing concept with mechanical precision down to the very finest detail.*

## Maximum performance at maximum load

The development of modern computers and electronic components has just one direction: ever more powerful, ever more compact. Components fitted shoulder to shoulder with a large degree of heat development demand maximum performance from the cooling system – and all on just a few square centimeters. The S-Force series answers these demands with its maximum cooling capacity. However, such enormous air performance figures subject the material to very high loads. The high speeds needed put a strain on the mechanics, the risk of resonance in the housing increases.

For this reason, every individual mechanical part in the new generation of fans has been completely newly-developed and adapted to the more stringent conditions. State-of-the-art computer simulation programs ensured that critical parameters were precisely calculated even before the first prototype was built. All components in the fan have been scrutinized for nominal speeds of up to 14,000 rpm. Special attention was given to the design of the impellers and to the profiles of the blades and the venturi housing. Together with a completely newly designed connection of the struts between the motor and housing, this allowed outstanding stability figures to be achieved, making the housing, stator and rotor “ready for action”, so to speak.

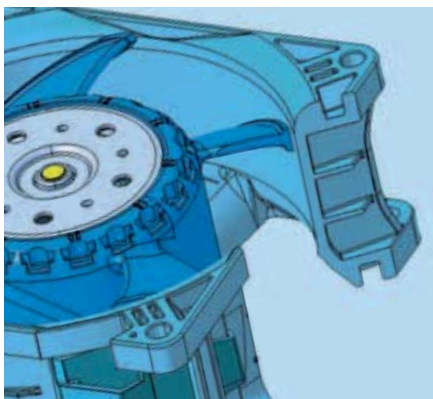



### **So that you can use it for a long time**

Besides absolute product functionality and cost-effectiveness, our quality standards with respect to durability are extremely high for all our products. The service life of our fans is decisively influenced by the quality of the bearing structure. Logically, the new generation of high-performance fans makes no compromise in this regard. Special bearing systems designed for the demands of very high speeds and highly resilient lubricants make a decisive contribution to the fact that every product achieves the excellent service life figures that you have come to expect from ebm-papst. This is confirmed both by our extensive service life tests and by scientifically recognized service life computations.

### **Hard exterior, gentle interior**

Wherever anything is turning at high speeds there will be vibrations. That is why higher speeds usually means increased noise levels. Moreover, resonant frequencies lead to a higher level of structure-borne noise input at certain operating points – the fan then becomes a body of sound. Additional reinforcements and the strut connections, together with the aerodynamic optimization of all components, systematically counter this phenomenon. This places our high-performance fans among the best in the world in terms of noise behavior, despite the far higher nominal speed.



# They all have one thing in common: they tell the air which way to go!

*Listening to our customers, developing new ideas to meet practical demands and then employing a pioneering spirit to put them into extremely economical top products. This philosophy has made ebm-papst the technological leader in the field of fans. With intelligent and innovative solutions such as our new compact fan generation, we devote our energy to securing your competitive edge with durable technology in top quality.*

## The strongest team in the league

The overall package of our new generation of compact fans is divided up into five series with sizes ranging from 80 to 172 mm. Each series represents the benchmark in its class with respect to air performance and pressure build-up. In a wide range of applications and operations, these high-performance fans are characterized by maximum cooling air flow at operating points with high backpressure, high motor efficiency and a long service life. Everywhere where a very high cooling capacity is needed, they are the solution – and there is practically no alternative. The following pages will give you a detailed overview of the technical data and areas of application for all our products.



*S-Force series 5300*

*S-Force series 6300*

*S-Force series 3200 J*

*S-Force series 4100 N*

*S-Force series 8200 J*

# S-Force Series 8200 J

- Highest pressure saddle and air flow in the 80 mm class
- Multi-strut housing, ball bearing system
- Impeller with winglets, blowing over struts
- Single-phase motor with high degree of efficiency (86 %)
- Applications: ATCA, IT and telecommunications, frequency inverters, medical, military

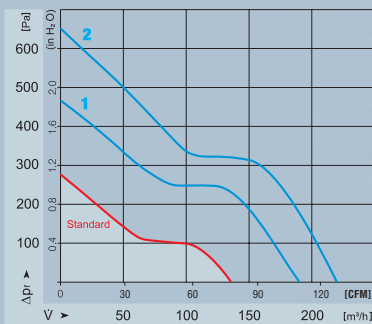
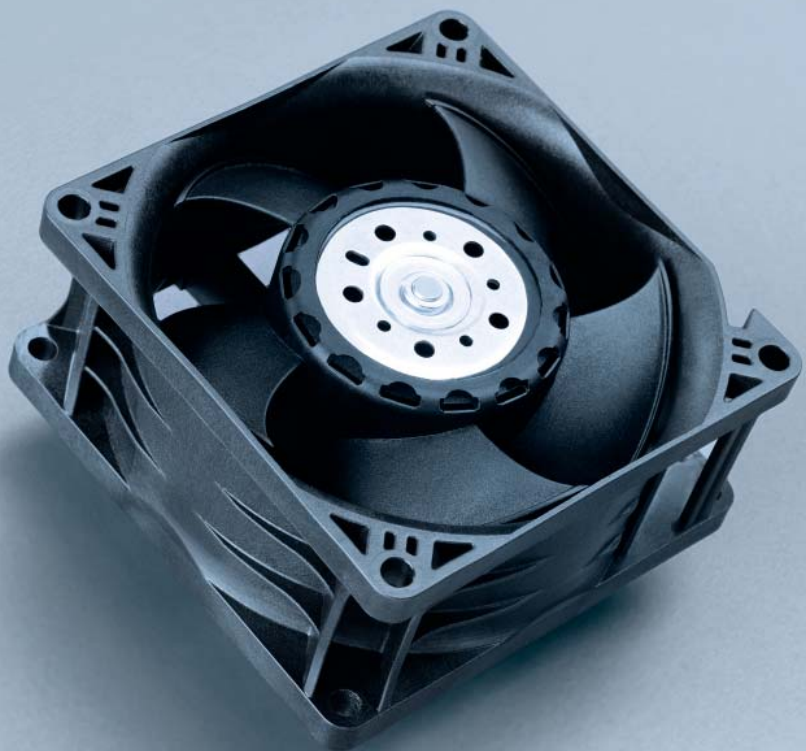
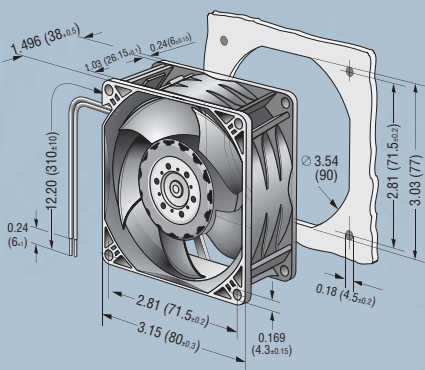

Nominal data	Air flow	Nominal voltage	Voltage range	Sound pressure	Power input	Nominal speed	Temperature range	Service life L <sub>10</sub> at 40 °C	Diagram curve
Type	CFM	V DC	V DC	dB(A)	Watts	rpm	°C	Hours	
8212 JH3	112	12	6...13.8	66	25	12,000	-20...+70	55,000	1
8212 JH4	131	12	6...13.8	71	39	14,000	-20...+70	50,000	2
8214 JH3	112	24	12...27.6	66	25	12,000	-20...+70	55,000	1
8214 JH4	131	24	12...27.6	71	37	14,000	-20...+70	50,000	2
8218 JH3	112	48	20...58	66	25	12,000	-20...+70	55,000	1
8218 JH4	131	48	20...58	71	37	14,000	-20...+70	50,000	2

# S-Force Series 3200 J

- Highest pressure saddle and air flow in the 92 mm class
- Multi-strut housing, ball bearing system
- Impeller with winglets, blowing over struts
- Single-phase motor with high degree of efficiency (89 %)
- Applications: IT and telecommunications, frequency inverters, medical, military

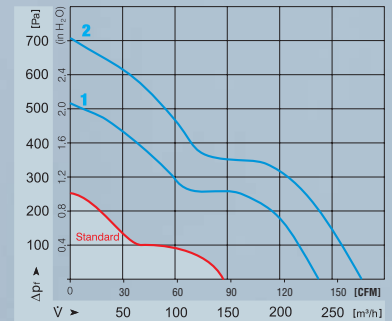
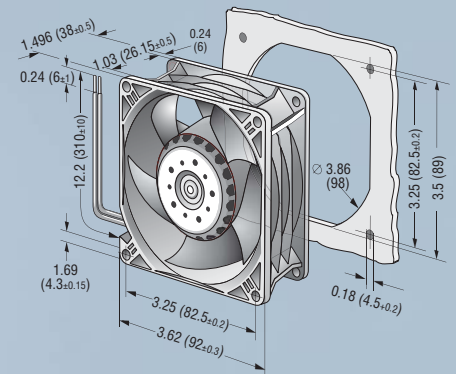

Nominal data	Air flow	Nominal voltage	Voltage range	Sound pressure	Power input	Nominal speed	Temperature range	Service life L <sub>10</sub> at 40 °C	Diagram curve
Type	CFM	V DC	V DC	dB(A)	Watts	rpm	°C	Hours	
3212 JH3	139	12	6...13.8	69	30	11,000	-20...+70	65,000	1
3212 JH4	165	12	6...13.8	73	50	13,000	-20...+70	60,000	2
3214 JH3	139	24	12...27.6	69	30	11,000	-20...+70	65,000	1
3214 JH4	165	24	12...27.6	73	50	13,000	-20...+70	60,000	2
3218 JH3	139	48	20...58	69	30	11,000	-20...+70	65,000	1
3218 JH4	165	48	20...58	73	50	13,000	-20...+70	60,000	2

# S-Force Series 4100 N

- Highest pressure saddle and air flow in the 120 mm class
- Broad range of operating voltages, 48 V design optionally available up to 72 V operating voltage
- Impeller sucking over struts, ball bearing system
- 3-phase drive with high degree of efficiency (85 %)
- Applications: ATCA, telecommunications, frequency inverters, switch cabinets, industrial applications, medical, military

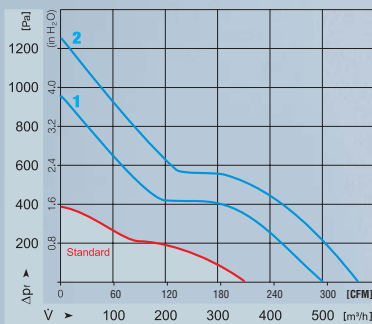
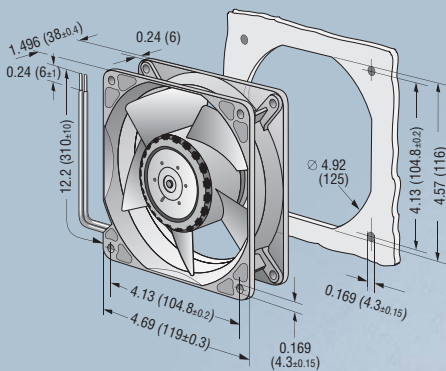

Nominal data	Air flow	Nominal voltage	Voltage range	Sound pressure	Power input	Nominal speed	Temperature range	Service life L <sub>10</sub> at 40 °C	Diagram curve
Type	CFM	V DC	V DC	dB(A)	Watts	rpm	°C	Hours	
4114 N/2H7P	294	24	16...30	76	90	9,500	-20...+75	57,500	1
4114 N/2H8P	335	24	16...30	78	120	11,000	-20...+75	55,000	2
4118 N/2H7P	294	48	36...60	76	90	9,500	-20...+75	57,500	1
4118 N/2H8P	335	48	36...60	78	120	11,000	-20...+75	55,000	2

# S-Force Series 5300

- The new 140 mm class from ebm-papst with outstanding performance data
- Highest pressure saddle and air flow in this size
- Impeller sucking over struts, ball bearing system
- 3-phase drive with high degree of efficiency (85 %)
- Applications: ATCA, servers, telecommunications, frequency inverters, switch cabinets, industrial applications, printing machinery, medical, military

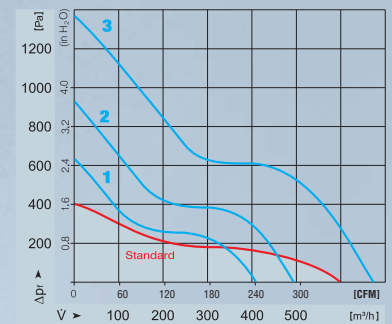
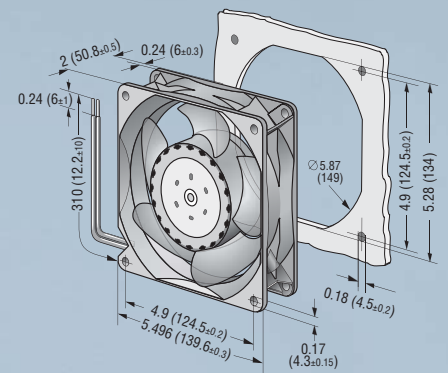
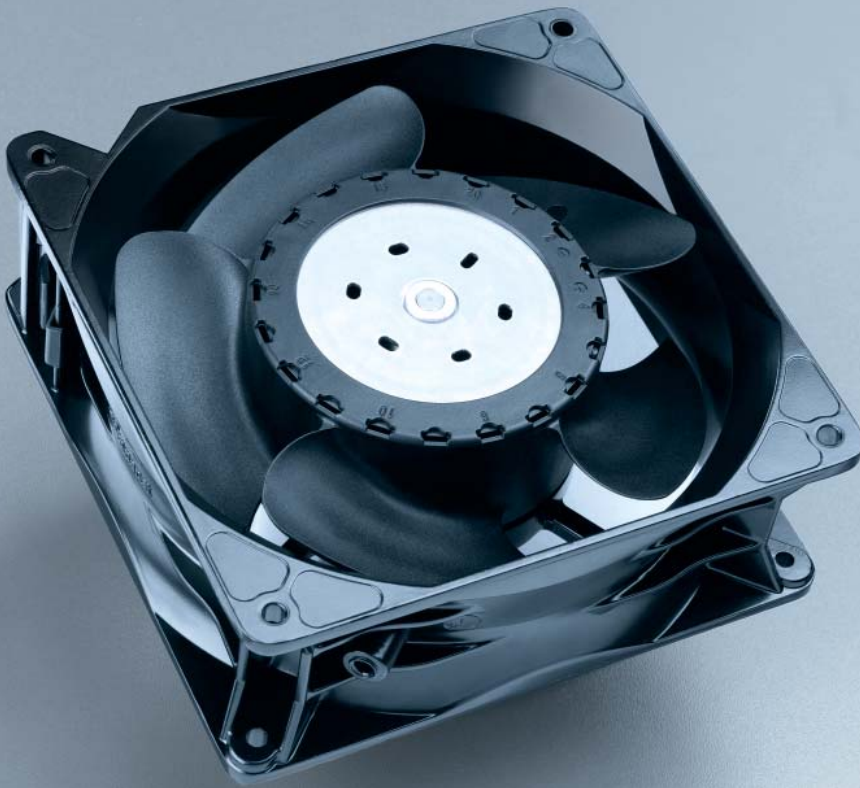

Nominal data	Air flow	Nominal voltage	Voltage range	Sound pressure	Power input	Nominal speed	Temperature range	Service life L <sub>10</sub> at 40 °C	Diagram curve
Type	CFM	V DC	V DC	dB(A)	Watts	rpm	°C	Hours	
5312 /2TDHP	241	12	8...16	70	41	6,000	-20...+70	70,000	1
5314 /2TDHP	241	24	16...36	70	41	6,000	-20...+70	70,000	1
5314 /2TDHHP	288	24	16...36	75	67	7,000	-20...+70	62,500	2
5318 /2TDHP	241	48	36...72	70	41	6,000	-20...+70	70,000	1
5318 /2TDHHP	288	48	36...72	75	67	7,000	-20...+70	62,500	2
5318 /2TDH4P	394	48	36...72	79	144	9,200	-20...+65	57,500	3

# S-Force Series 6300

- Highest pressure saddle and air flow in the 172 mm class
- These fans achieve the pressure values of diagonal compact fans of the same size
- Impeller with sickle-blades and winglets, blowing over struts, ball bearing system
- 3-phase drive with high degree of efficiency (85 %)
- Applications: telecommunications, frequency inverters, switch cabinets, industrial applications, printing machinery, medical, military

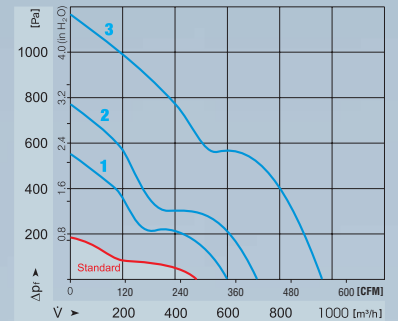
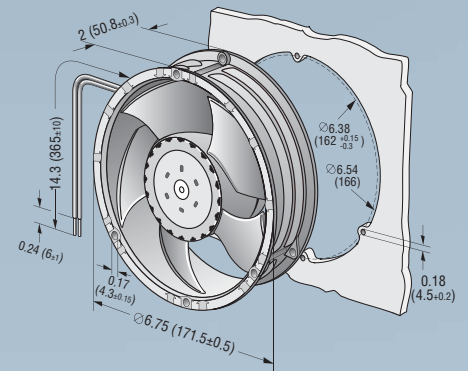

Nominal data	Air flow	Nominal voltage	Voltage range	Sound pressure	Power input	Nominal speed	Temperature range	Service life L <sub>10</sub> at 40 °C	Diagram curve
Type	CFM	V DC	V DC	dB(A)	Watts	rpm	°C	Hours	
6312 /2TDHP	353	12	8...16	64	41	6,000	-20...+70	70,000	1
6314 /2TDHP	353	24	16...36	64	41	6,000	-20...+70	70,000	1
6314 /2TDHHP	418	24	16...36	69	67	7,000	-20...+70	62,500	2
6318 /2TDHP	353	48	36...72	64	41	6,000	-20...+70	70,000	1
6318 /2TDHHP	418	48	36...72	69	67	7,000	-20...+70	62,500	2
6318 /2TDH4P	559	48	36...72	75	150	9,200	-20...+65	52,500	3

### **Development, Production and Delivery from a single source**

*At ebm-papst, the development and production of motors, fans and electronics is all managed at a single source. This guarantees that all components are perfectly matched to one another and produce optimum performance. It is of course only logical that just-in-time delivery and logistics are also managed from a single source. Whether it be in Germany or at any of our international locations: We offer you first-class service and logistics, from local technical support through to inventory management.*

#### **ebm-papst St. Georgen GmbH & Co. KG**

Hermann-Papst-Straße 1  
78112 St. Georgen  
Germany  
Phone +49 (0) 7724 / 81-0  
Fax +49 (0) 7724 / 81-1309  
info2@de.ebmpapst.com

[www.ebmpapst.com](http://www.ebmpapst.com)

#### **ebm-papst Inc. Farmington, CT USA**

100 Hyde Road  
Farmington, CT 06034  
USA  
Phone +1 860 674 1515  
Fax +1 860 674 8536  
sales@us.ebmpapst.com

[www.ebmpapst.us](http://www.ebmpapst.us)