



Hochschule Aachen

I.F.I. Institut
für Industrieaerodynamik GmbH
Institute at the
Aachen University
of Applied Sciences

Welkenrather Straße 120
D – 52074 Aachen
Germany

Tel.: +49 241/879708-0
Fax: +49 241/879708-10
E-mail: info@ifi-aachen.de

Notified testing laboratory, inspection
body and certification body no. 1368
according to the CPD

Client: SMAY Sp. Z.o.o.
Project no. DDS10-02
Report no.: DDS10-02-1

Test Report

Pressure Differential System iSWAY-FC

This test report contains 13 pages, 3 annexes and a summary of test results.

Test Engineer: Dipl.-Ing. W. Mertens, M.Sc.

Aachen, September 29, 2010

Dipl.-Ing. B. Konrath

Dipl.-Ing. W. Mertens, M.Sc.

Directors:
Dipl.-Ing. B. Konrath, Dipl.-Ing. R.-D. Lieb
Advisory Board:
Prof. Dr.-Ing. H.J. Gerhardt, Prof. Dr.-Ing. R. Grundmann
Prof. Dr.-Ing. H. Funke, Prof. Dr.-Ing. Th. Heynen

Sparkasse Aachen
Kto.-Nr. 47 440 003
BLZ 390 500 00

Commerzbank AG Aachen
Kto.-Nr. 3 006 848
BLZ 390 400 13

District Court Aachen
HRB 4518

Contents

1	Mission statement.....	3
2	Results	3
3	Test philosophy	3
3.1	Tests	5
3.1.1	Functionality test.....	5
3.1.2	Dynamic behavior test.....	5
3.1.3	Reliability test.....	6
3.1.4	Durability test	6
3.1.5	Resonance test.....	6
3.1.6	Testing procedure for modified performance classes	6
3.2	Designations and definitions	7
3.3	Test criteria	8
4	Description of tested system	8
4.1	Description	8
4.2	System components	9
5	Analysis	9
5.1	Analysis of performance class 1	12
5.2	Analysis of performance class 2	12

1 Mission statement

The pressure differential systems (DDS) will be tested in accordance with the revised edition of EN DIN 12101-6, which is expected to be published in 2010/2011. The test will establish the characteristic system specifications.

2 Results

Table 2.1 shows the two tests with the final results for the two different performance classes:

Performance class	\dot{V}_N [m ³ /h]	\dot{V}_L [m ³ /h]	Δp_N [Pa]	Δp_V [Pa]	Re _n [-]	A _T [m ²]	Results
1	15,800	1,000	45	12	10,000	2.19	passed
2	15,600	2,000	45	12	10,000	2.17	passed

Table 2.1 Results

\dot{V}_N	rated volumetric flow rate	Δp_V	pressure differential across exhaust flow
\dot{V}_L	volumetric leakage flow rate	Re _n	number of cycles in continuous test
Δp_N	nominal pressure difference	A _T	maximum door size for v = 2 m/s

3 Test philosophy

A pressure differential system consists of at least one device for volumetric flow supply coupled with a pressure controller. The volumetric flow supply is typically achieved with a fan; volumetric flow rate and pressure can be controlled in very different ways.

The system is designed to prevent smoke from entering a security area. Fresh air is supplied to the protected area through leaks and open doors in the direction of the fire room, thus pushing the smoke back into the fire zone. Typically, the security area is an anteroom to a staircase or an anteroom to an emergency lift. Pressure differential systems are therefore mostly installed in stairways. As specified by the standard, the pressure difference between safety zone and fire zone with the door closed is derived from a maximum door opening force of 100 N. Door closing torque and door shape are also taken into consideration. The volumetric flow through the connecting door is based on the requirement of the standard for an average speed of

2 m/s through the door cross-section to the fire room or storey. The leaks in a staircase add up to a volumetric leakage flow, which, when added to the volumetric flow through the corridor, defines the total volumetric flow to be supplied by the fan. The establishment of the desired volumetric flow when the connecting door is opened, and the regulation of the pressure to the rated value as a function of door size when the connecting door is closed, must be completed within a pre-defined time period. In practice, the air flowing into the fire zone can be exhausted via the designated area and the facade or through a shaft; the exhaust flow may also be supported mechanically. The pressure loss, due to the flow along this route, affects the performance of the pressure controller and fan.

The test is carried out in the test room at the I.F.I. Institute for Industrial Aerodynamics GmbH, Institute at the University of Applied Sciences Aachen – called I.F.I. below. The volume of the test room is $(5.25 \times 4.55 \times 4) \text{ m}^3$. The layout of the test room is shown in Fig. 1.1.

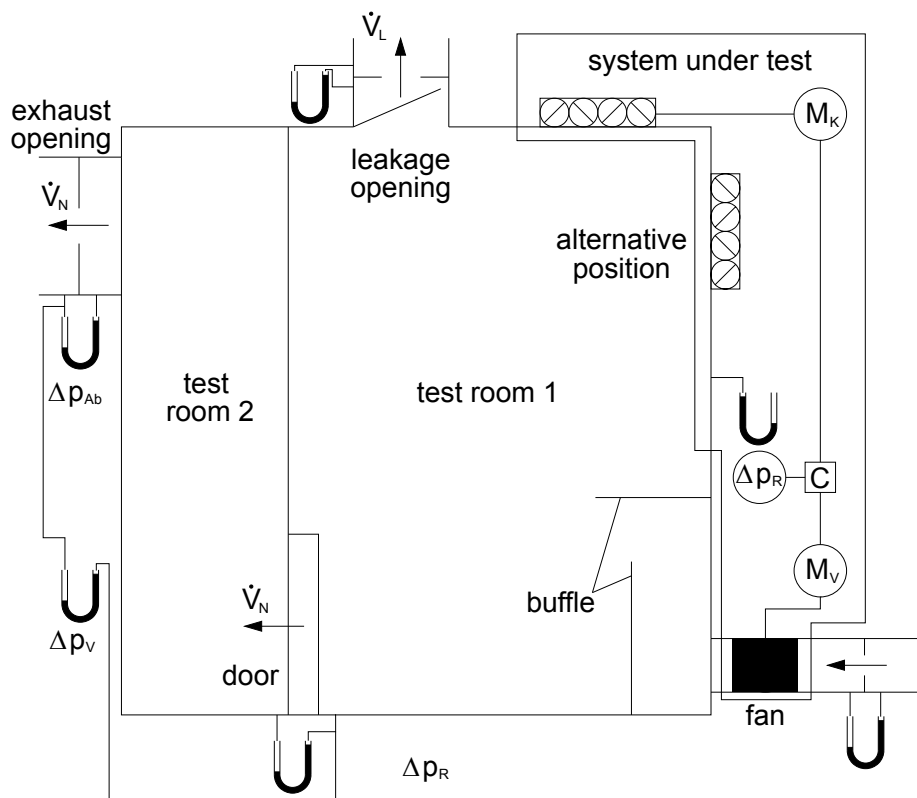

Fig. 1.1 Test room

3.1 Tests

The test comprises a number of subtests:

- functionality test , Fu
- reliability test , Re
- durability test, Du
- resonance test, Res
- dynamic behavior test, DB

3.1.1 Functionality test

In the functionality test (Fu) a door that has just been delivered is repeatedly opened and closed in the same manner to test the behavior of the DDS. The dynamic behavior test (DB) is run to test functionality. The functionality test is run before the continuous test.

3.1.2 Dynamic behavior test

The dynamic behavior test (DB) describes a repeated door operation. A door operation cycle is broken down into its constituent components and plotted against time (Fig. 2.1).

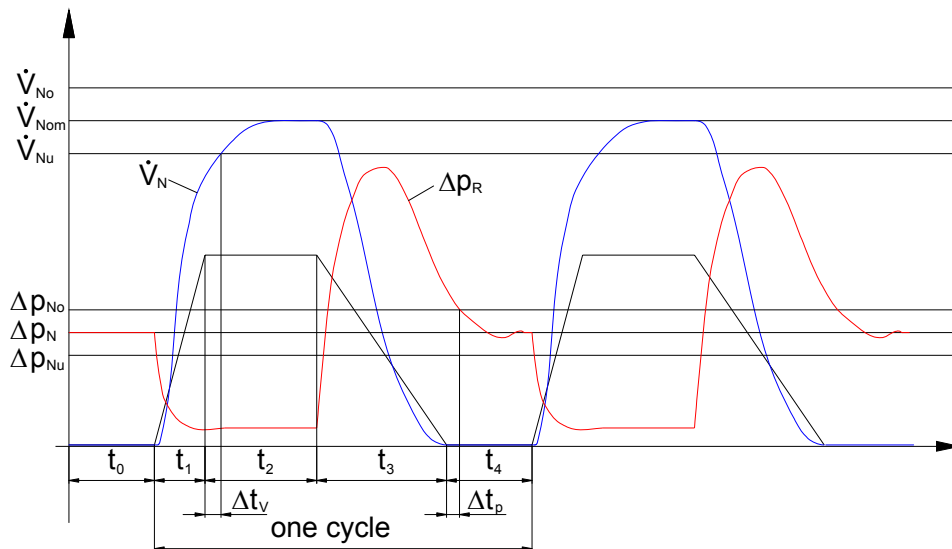

Fig. 2.1 DB cycle

- t_0 start delay (occurs only once)
- t_1 door opening time 1 s
- t_2 time to establish volumetric flow 6 s
- t_3 door closing time 3 s
- t_4 pressure control delay time 6 s

The cycle t_1 to t_4 runs 20 times in the DB. Time to establish volumetric flow Δt_v and pressure regulation time Δt_p in every cycle are evaluated.

3.1.3 Reliability test

In the reliability test (Re) the cycle described in the previous section is run 10,000 times. Individual values are not measured and there is no evaluation during the cycles. The reliability test is passed when, after the test is complete, the DDS is able to deliver the rated volumetric flow into the fire storey through the opened door.

3.1.4 Durability test

The durability test (Du) has the same functionality and sequencing as the dynamic behavior test; and it detects any deviation from the basic functionality of the system under investigation after the continuous test has been completed (impact of ageing).

3.1.5 Resonance test

The resonance test (Res) consists of a number of subtests. In this test the impact a door has on the control response, when the door is not fully closed between opening operations, is simulated. The subtests consist of 20 cycles with delay times t_2 and t_4 set to zero. The open period t_3 is adapted in each test and reduced from 3 s to 1 s in 0.5-second intervals. The establishment of volumetric flow and pressure control response are checked for each time combination after 20 cycles. The resonance test determines whether a control system tends to resonate. The resonance test is run after the reliability test; it may also be run before the reliability test, to determine any impacts due to ageing.

3.1.6 Testing procedure for modified performance classes

The dynamic behavior test and resonance test must be run again if a new set of performance classes are introduced for the same DDS. This is the case if one or more of the performance classes rated volumetric flow rate, rated pressure, volumetric leakage flow and exhaust pressure loss are altered.

3.2 Designations and definitions

The definitions below are used in the report:

Designation	Unit	Description
\dot{V}_N	m ³ /h	Volumetric flow delivered from test room 1 (staircase) to test room 2 (fire zone)
\dot{V}_{Nom}	m ³ /h	Rated volumetric flow delivered from test room 1 (staircase) to test room 2 (fire zone) with the door fully open
\dot{V}_L	m ³ /h	Volumetric leakage flow exhausted from the test room (test room, staircase) at nominal pressure differential with the corridor closed
\dot{V}_{Nu}	m ³ /h	Lower limit of rated volumetric flow – must be reached within time period Δt_p after the door has been opened – $\dot{V}_{Nu} = 0.9 * \dot{V}_N$
Δp_R	Pa	Pressure differential between test room and surrounding
Δp_N	Pa	Nominal pressure differential to be maintained by the DDS with the door closed
Δp_V	Pa	Pressure differential across the exhaust flow with the door open
Δp_{No}	Pa	Upper limit value of nominal pressure differential – the nominal pressure differential must drop below this limit value within the time period Δt_p after the door has been closed – $\Delta p_{No} = 1,2 * \Delta p_N$
Δp_{Nu}	Pa	Lower limit value of nominal pressure differential – the nominal pressure differential should not drop below this limit value in the regulated steady state with the door closed – $\Delta p_{Nu} = 0,8 * \Delta p_N$
Δp_{Ab}	s	Pressure differential across exhaust opening
t_A	s	Time when the corridor is fully opened
t_C	s	Time when the corridor is fully closed
t_D	s	Time when \dot{V}_{Nu} is exceeded
t_E	s	Time when the pressure differential Δp_R is less than Δp_{No}
Δt_V	s	Time period needed to establish volumetric flow $t_D - t_A$
Δt_p	s	Pressure regulation time period $t_E - t_C$
$\Delta t_{V,i}$	s	Time to establish volumetric flow in DB cycle i
$\Delta t_{p,i}$	s	Pressure regulation time in DB cycle i
n	-	Number of cycles in DB – n = 20
A_T	m ²	Maximum door size, which allows an average speed of 2 m/s with flow through the door at volumetric flow rate \dot{V}_N
Re_n	-	Number of test cycles in the reliability test

3.3 Test criteria

The test criterion to establish volumetric flow is said to be passed when the time period $\Delta t_{v,i}$ in DB, or the time period Δt_v in each subtest in the resonance test, is less than or equal to 3 s.

$$\text{criterion for establishing volumetric flow DB} \quad \Delta t_{v,i} \leq 3 \text{ s} \quad (1)$$

$$\text{criterion for establishing volumetric flow Res} \quad \Delta t_v \leq 3 \text{ s} \quad (2)$$

The pressure control criterion is said to be passed when the averaged time period $\Delta t_{p,i}$ in DB, or the time period Δt_p in each subtest in the resonance test, is less than or equal to 3 s. In the regulated state the pressure should not fall below 80% of the rated pressure.

$$\text{pressure control criterion DB} \quad \Delta t_{p,i} \leq 3 \text{ s} \quad (3)$$

$$\text{pressure control criterion Res} \quad \Delta t_p \leq 3 \text{ s} \quad (4)$$

$$\text{lower pressure limit criterion} \quad \Delta p_R \geq \Delta p_{Nu} \quad (5)$$

4 Description of tested system

Manufacturer/supplier: SMAY Sp. z o.o – Krakow, Poland

System designation: iSWAY-FC®

4.1 Description

The system consists of a fan with a louver damper fitted to its outlet. The fan is driven by a frequency converter; the louver damper is actuated by a Belimo actuator. The controller uses the differential pressure signal between test room and ambient as a reference input variable to control the louver damper. The pressure differential between ambient and fan outlet is used as reference input variable to control the FU. Exhaust flow from the test room with the door closed occurs via the leakage points only; there is no other pressure relief vent from test room to ambient. Annex A contains two system diagrams and the fan specifications. Annex B contains images of the test rig and components. Annex C contains the test diagrams.

4.2 System components

Fan

Manufacturer	Venture Industries Sp. z. o.o. – Kielpin, Poland
Type	AFC/4-800-400

Louver damper

Manufacturer	SMAY Sp. z.o.o
Type	PWII-S
Size	800x800 mm
Drive	Belimo NMQ24A-SRV-S

Controller

Control panel	SMAY Sp. z o.o
FU	Danfoss VLT [®] Automation Drive FC 302 – 4kW
Controller	URBS

URBS controller (1x controller FU, 1x controller motor louver damper) consists of:

Pressure sensor	Belimo VFP30
Controller	Belimo VRP-M

5 Analysis

One test with the performance classes below are run in addition to the standard test:

Test no.	Performance class			
	\dot{V}_N [m ³ /h]	\dot{V}_L [m ³ /h]	Δp_N [Pa]	Δp_V [Pa]
1	15,800	1,000	45	12
2	15,600	2,000	45	12

Table 5.1 Test variants

Figures 5.1 to 5.4 show the outline sketches of the functionality test and the durability test of the performance classes 1 and 2. Tables 5.2 to 5.5 contain the test results and general data for each class.

DDS10-02-02 - SMAY Sp. z o.o. - iSWAY-FC®
Functionality - Performance class 1

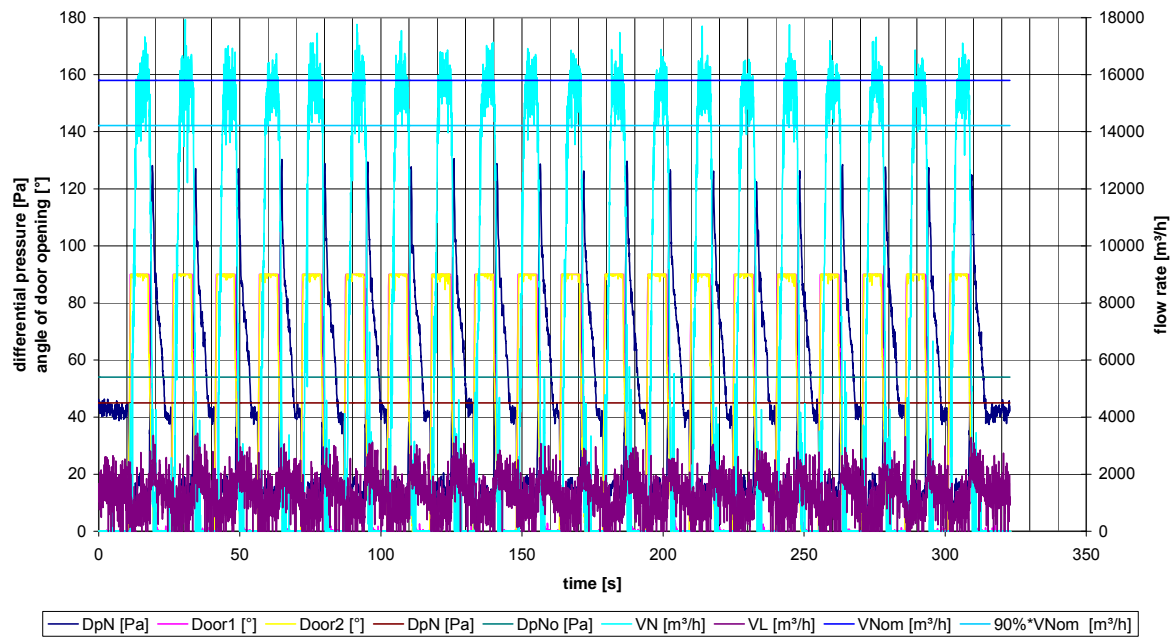

Fig. 5.1 Fu performance class 1

DDS10-02-07 - SMAY Sp. z o.o. - iSWAY-FC®
Durability - Performance class 1

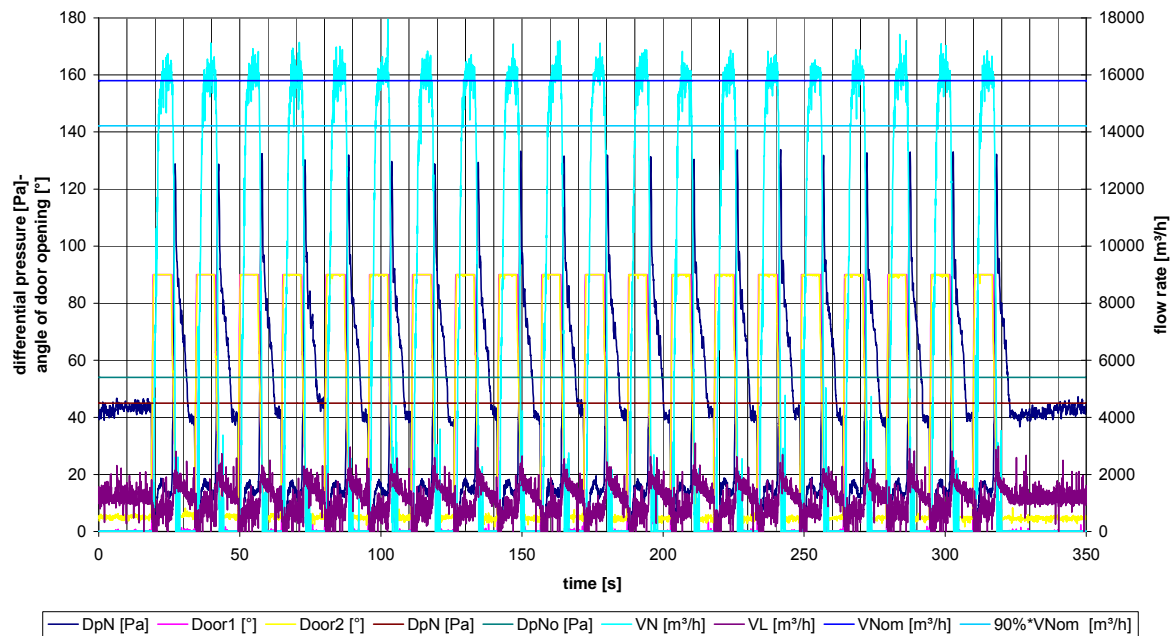

Fig. 5.2 Du performance class 1

DDS10-02-03 - SMAY Sp. z o.o. - iSWAY-FC®
Functionality - Performance class 2

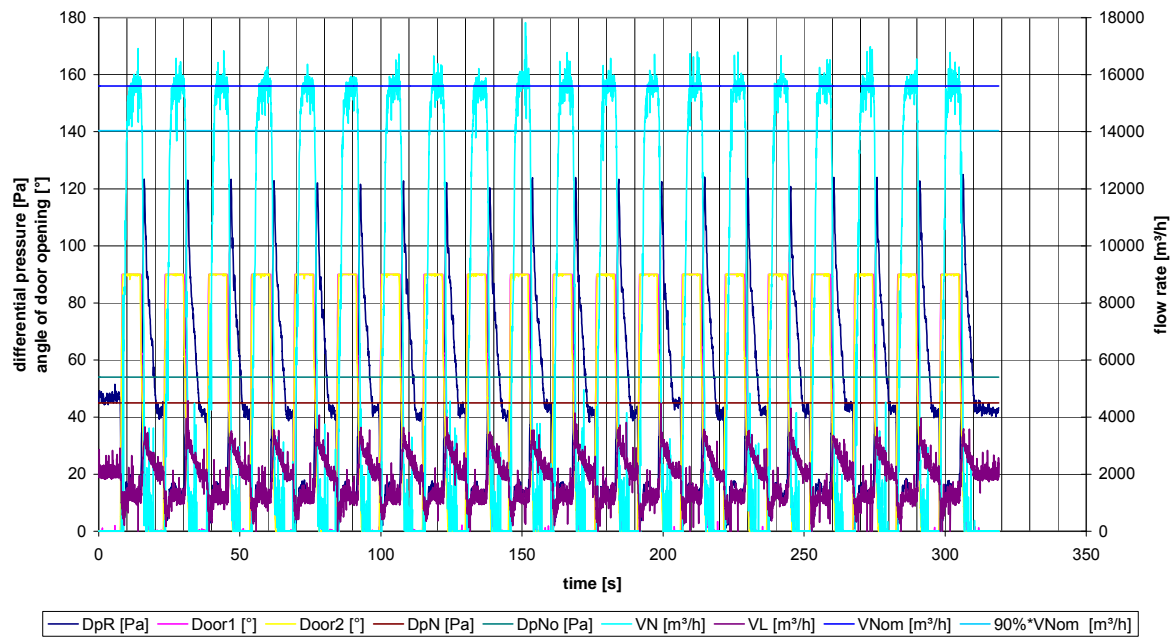

Fig. 5.3 Fu performance class 2

DDS10-02-29 - SMAY Sp. z o.o. - iSWAY-FC®
Durability - Performance class 2

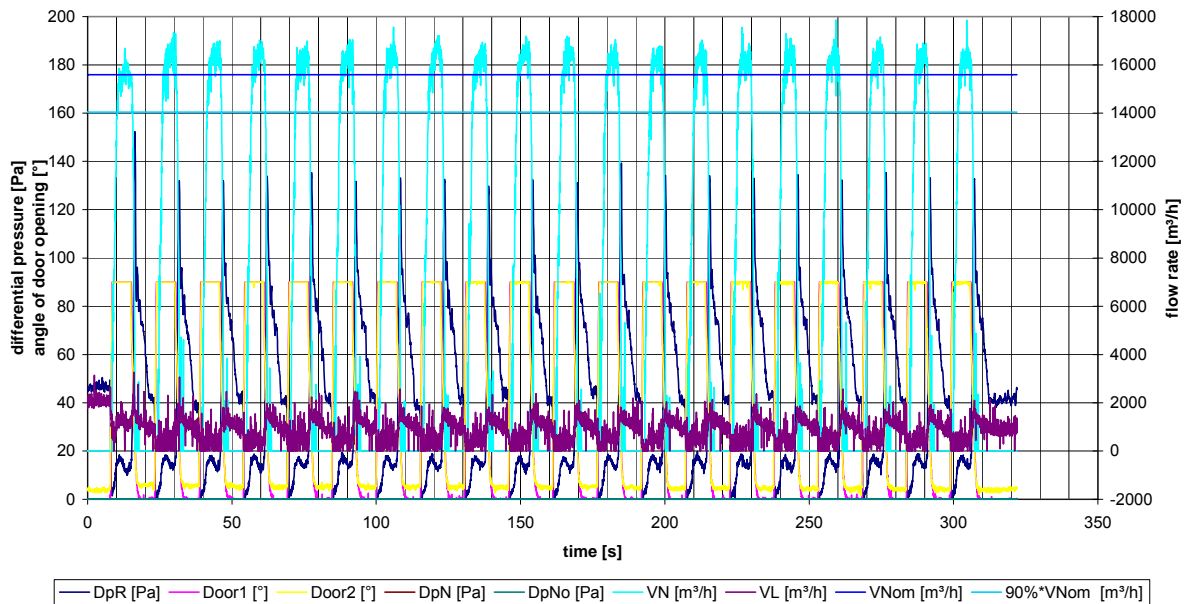

Fig. 5.4 Du performance class 2

5.1 Analysis of performance class 1

SMAY Sp. z o.o. - iSWAY-FC®			
Performance class 1			
V_N [m ³ /h]	V_L [m ³ /h]	Δp_N [Pa]	Δp_V [Pa]
15800	1000	45	12

Table 5.2 General data

SMAY Sp. z o.o. - iSWAY-FC®					
Table of results - performance class 1					
Test	t_3 [s]	Δp_{Nu} [Pa]	Δt_V [s]	Δt_p [s]	Result
Fu		ok	2,2	2,6	passed
Rel					passed
Du		ok	2,1	2,4	passed
Res 1	3,0	ok		1	passed
Res 2	3,0		0,7		passed
Res 3	2,5	ok		1,7	passed
Res 4	2,5		0,3		passed
Res 5	2,0	ok		1,8	passed
Res 6	2,0		0,3		passed
Res 7	1,5	ok		1,9	passed
Res 8	1,5		0		passed
Res 9	1,0	ok		2,3	passed
Res 10	1,0		0		passed
Res					passed

Table 5.3 Test result

5.2 Analysis of performance class 2

SMAY Sp. z o.o. - iSWAY-FC®			
Performance class 2			
V_N [m ³ /h]	V_L [m ³ /h]	Δp_N [Pa]	Δp_V [Pa]
15600	2000	45	12

Table 5.4 General data

SMAY Sp. z o.o. - iSWAY-FC®					
Table of results - performance class 2					
Test	t₃ [s]	Δp_{Nu} [Pa]	Δt_v [s]	Δt_p [s]	Result
Fu		ok	2,3	1,8	passed
Rel					passed
Du		ok	2,5	2,5	passed
Res 1	3,0	ok		1,8	passed
Res 2	3,0		2,5		passed
Res 3	2,5	ok		2,3	passed
Res 4	2,5		0,6		passed
Res 5	2,0	ok		3	passed
Res 6	2,0		0,3		passed
Res 7	1,5	ok		2,3	passed
Res 8	1,5		0		passed
Res 9	1,0	ok		2,4	passed
Res 10	1,0		0		passed
Res			1		passed

Table 5.5 Test result

A n n e x A

Report DDS10-02-1

SMAY Sp. z o.o
Pressure differential system iSWAY-FC®

- Schematic diagrams -

Report Nr. DDS10-02-1 (Annex A)
SMAY – iSWAY-FC®
- Schematic Diagrams -

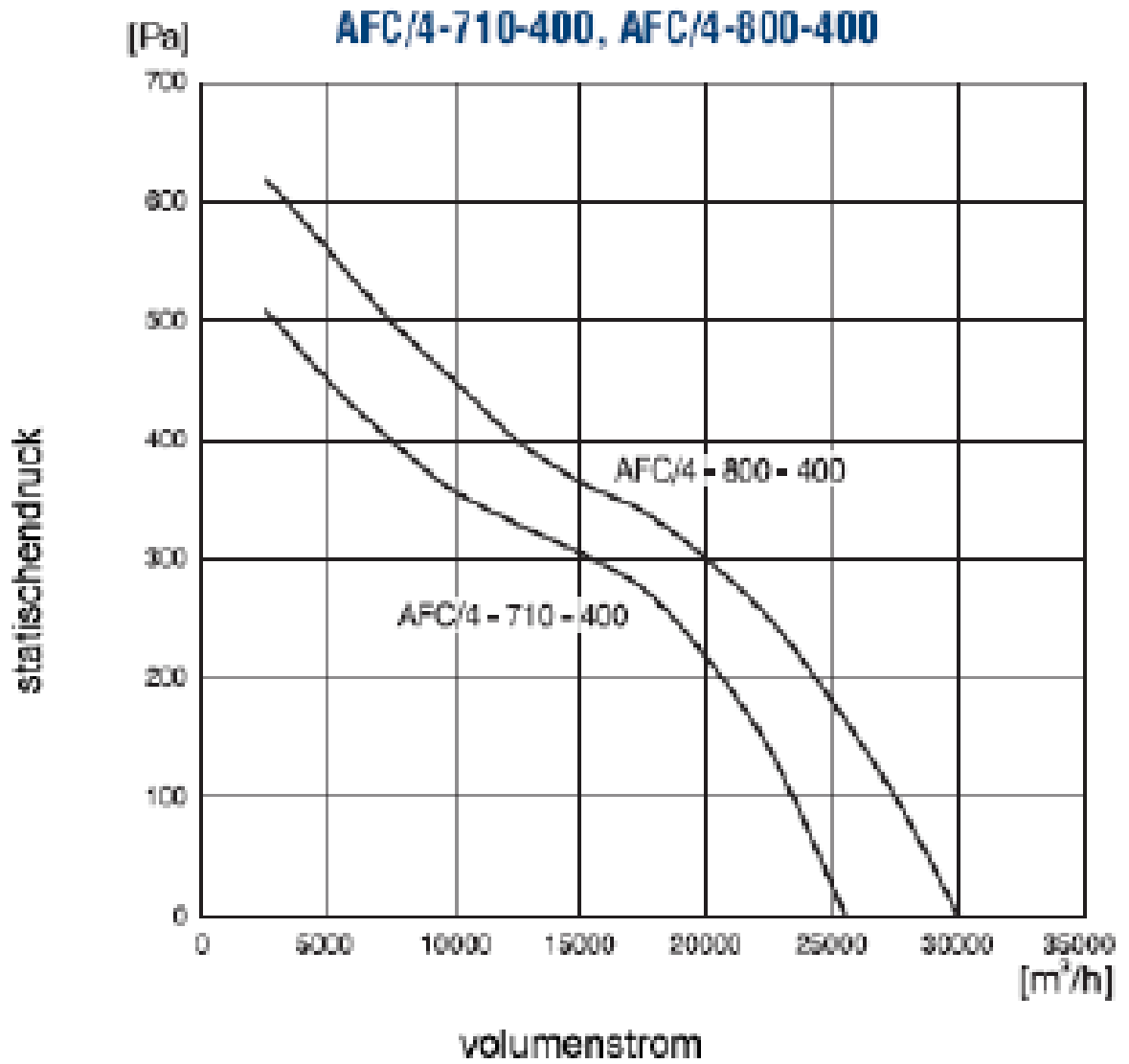

A n n e x B

Report DDS10-02-1

SMAY Sp. z o.o
Pressure differential system iSWAY-FC®

- System Images -



Fig. 1 Pressure differential system iSWAY-FC® with volumetric flow measurement system in front of test room

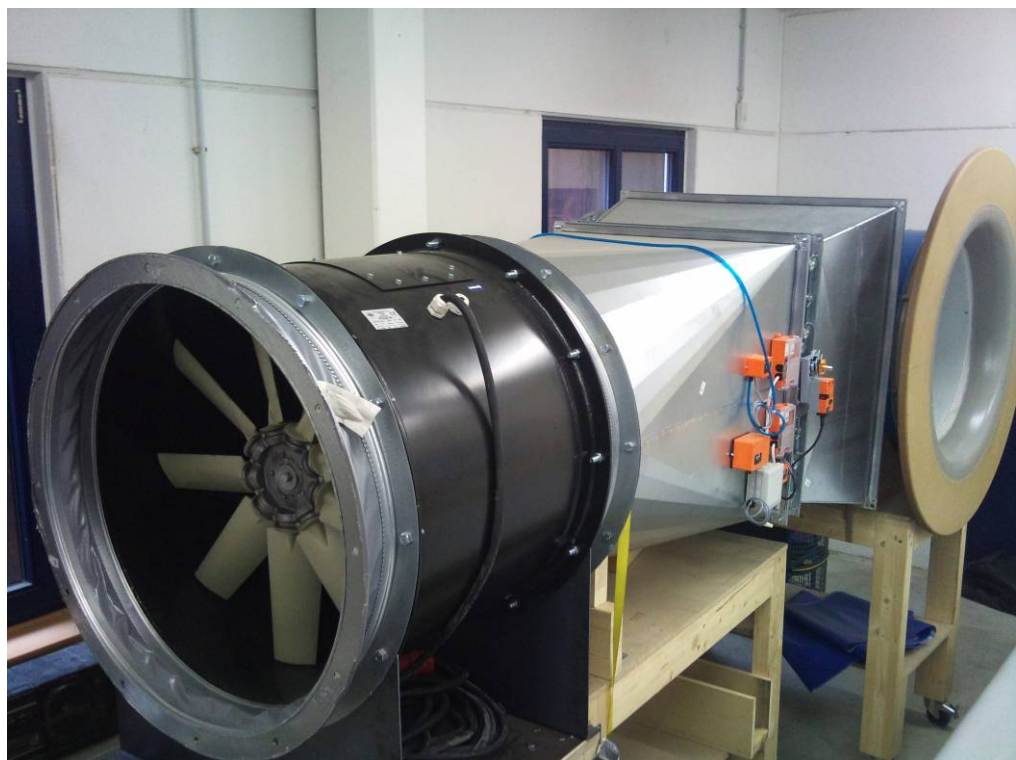

Fig. 2 Pressure differential system iSWAY-FC® with control unit

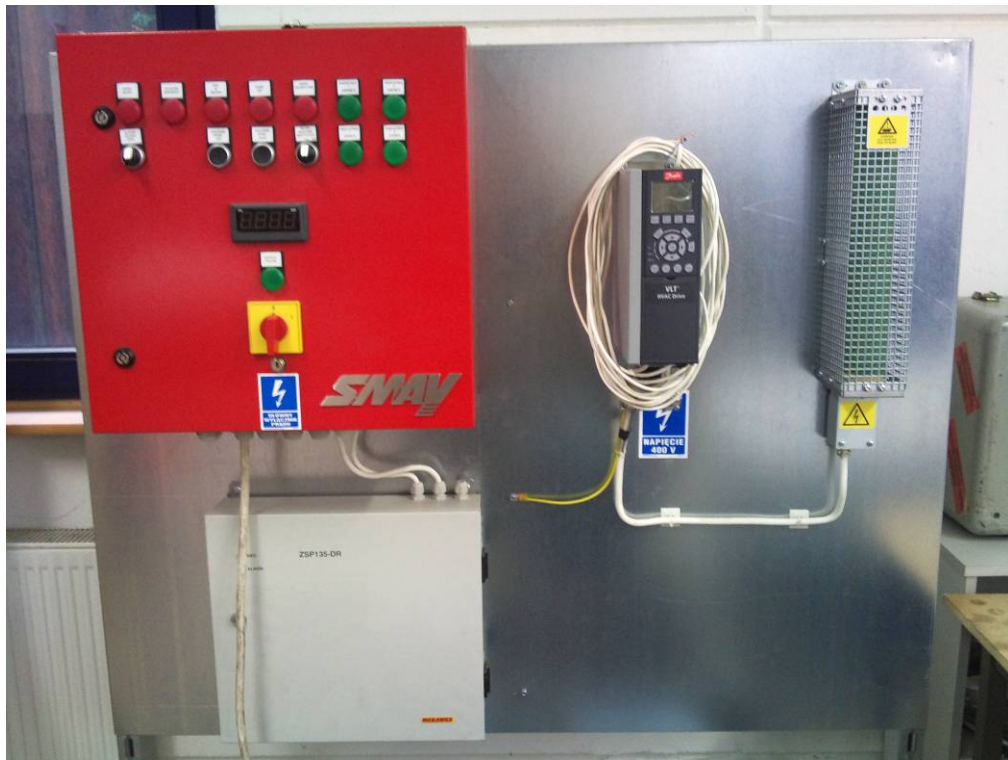

Fig. 3 Control unit, power supply and frequency converter



Fig. 4 Fan model plate



Fig. 5 iSWAY-FC® control components with louver damper SMAY PWII-S



Fig. 6 Belimo VFP300 pressure differential sensor



Fig. 7 Controller Belimo VRP-M



Fig. 8 Drive for louver damper Belimo NMQ24A-RV-ST

A n n e x C

Report DDS10-02-1

SMAY Sp. z o.o
Pressure differential system iSWAY-FC®

- Test Drawings -

Report Nr. DDS10-02-1 (Annex C)
SMAY – iSWAY-FC®
- Test Drawings -

Index of contents

Performance Class 1 – Functionality.....	3
Performance Class 1 – Durability	3
Performance Class 1 – Resonance test.....	4
Performance Class 2 – Functionality.....	9
Performance Class 2 – Durability	9
Performance Class 2 – Resonance test.....	10

Performance Class 1 – Functionality

DDS10-02-02 - SMAY Sp. z o.o. - iSWAY-FC®
Functionality - Performance class 1

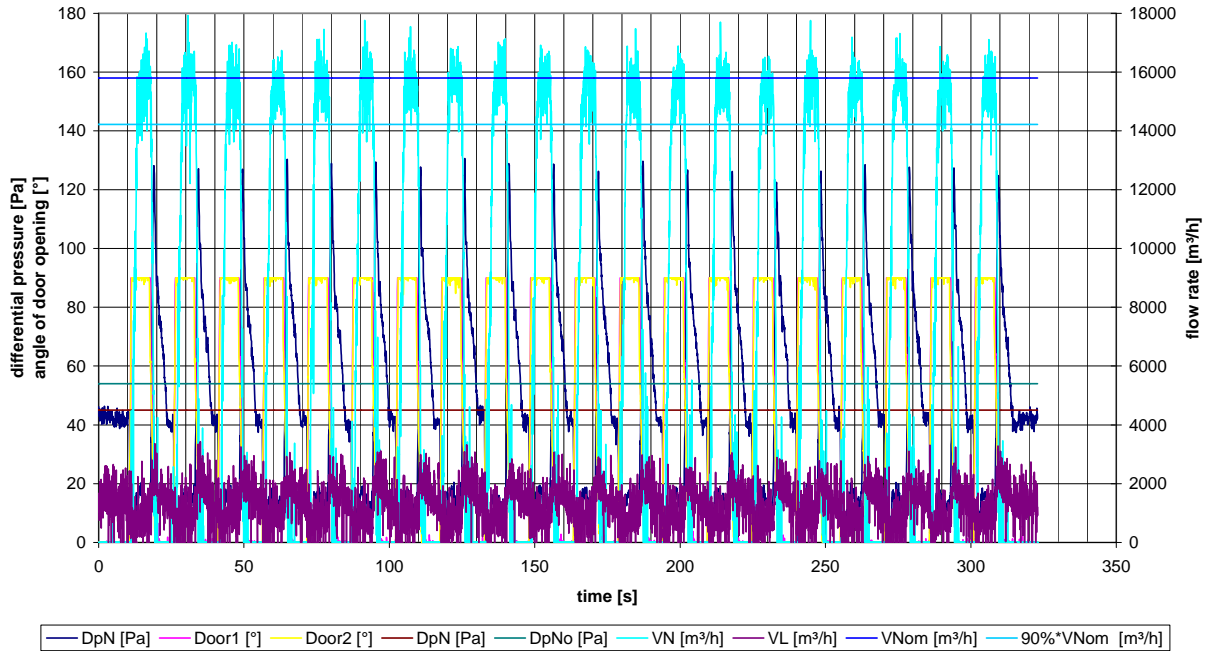

Performance Class 1 – Durability

DDS10-02-07 - SMAY Sp. z o.o. - iSWAY-FC®
Durability - Performance class 1

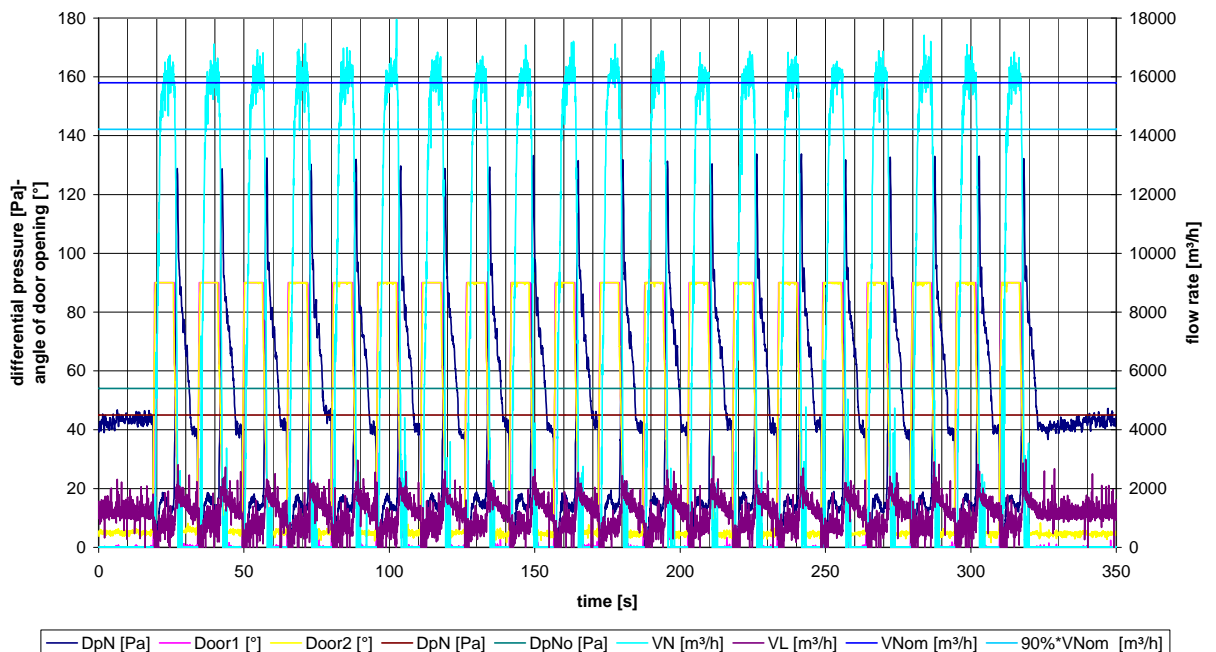

Report Nr. DDS10-02-1 (Annex C)
SMAY – iSWAY-FC®
- Test Drawings -

Performance Class 1 – Resonance test

DDS10-02-08 - SMAY Sp. z o.o. - iSWAY-FC®
 Resonance Test - t1=1s - t3=3s - Performance class 1

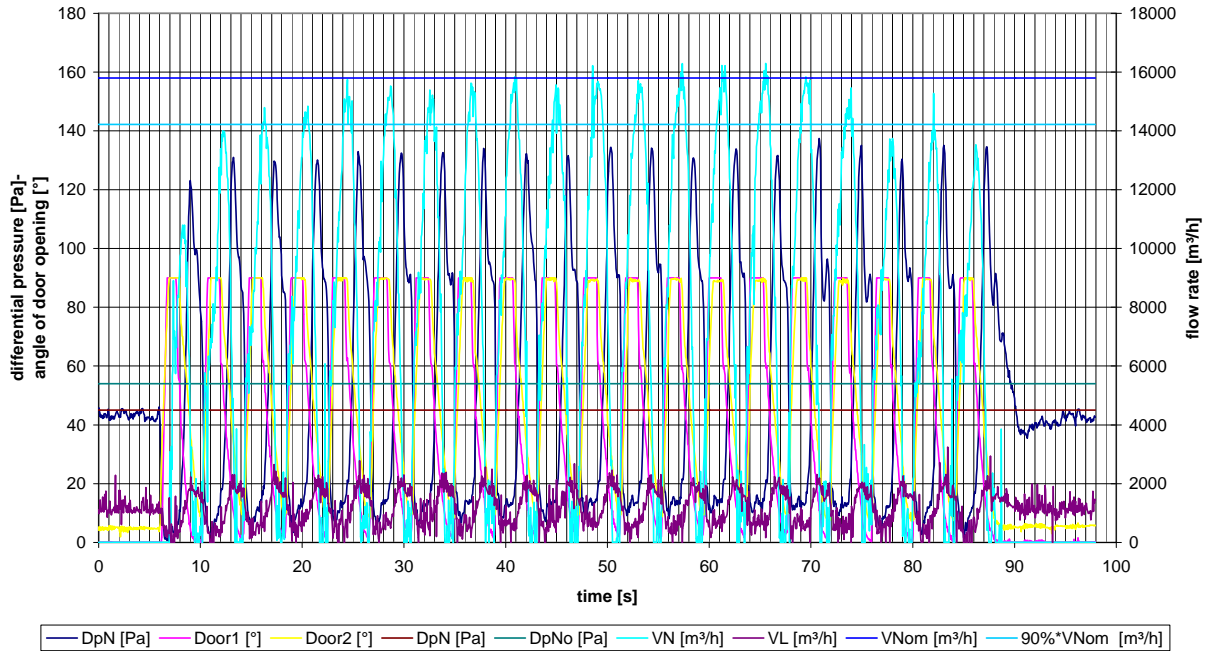

DDS10-02-09 - SMAY Sp. z o.o. - iSWAY-FC®
 Resonance Test - t1=1s - t3=3s - Performance class 1

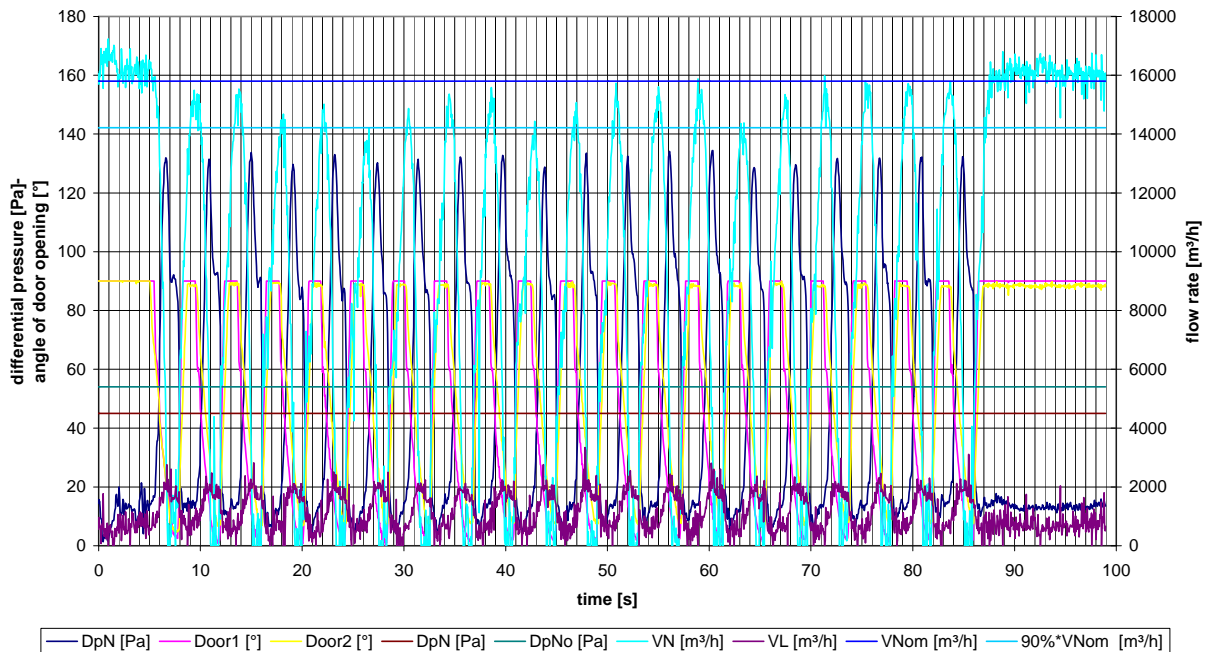

Report Nr. DDS10-02-1 (Annex C)
 SMAY – iSWAY-FC®
 - Test Drawings -

DDS10-02-10 - SMAY Sp. z o.o. - iSWAY-FC®
 Resonance Test - t1=1s - t3=2,5s - Performance class 1

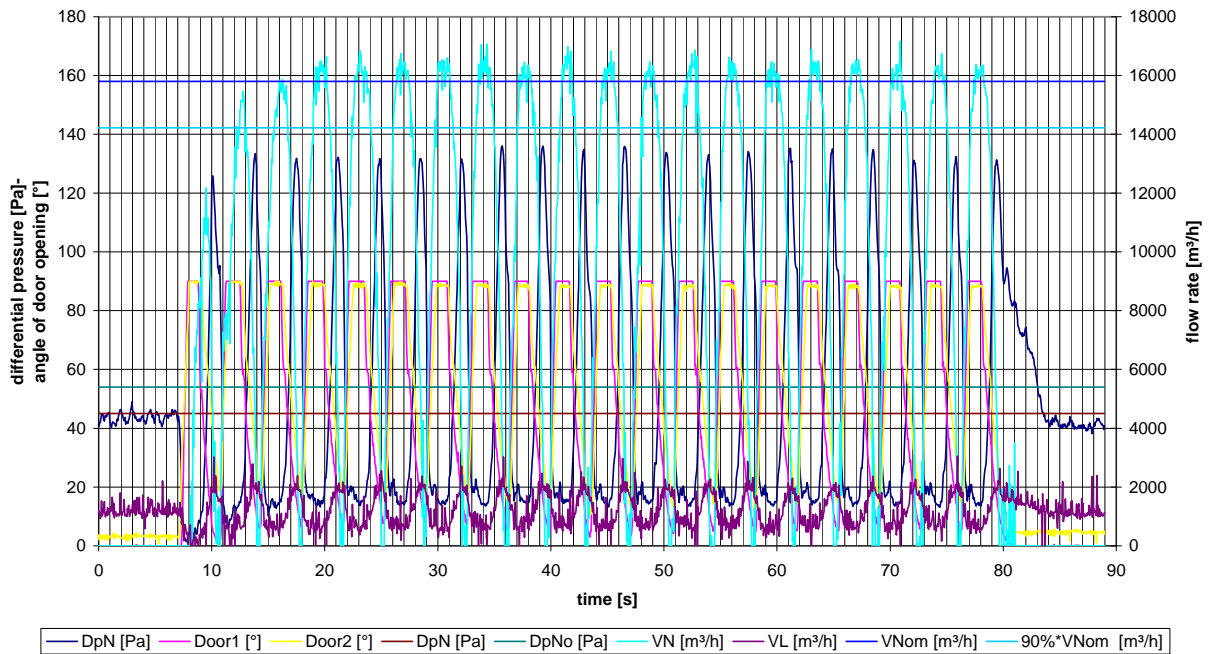

DDS10-02-11 - SMAY Sp. z o.o. - iSWAY-FC®
 Resonance Test - t1=1s - t3=2,5s - Performance class 1

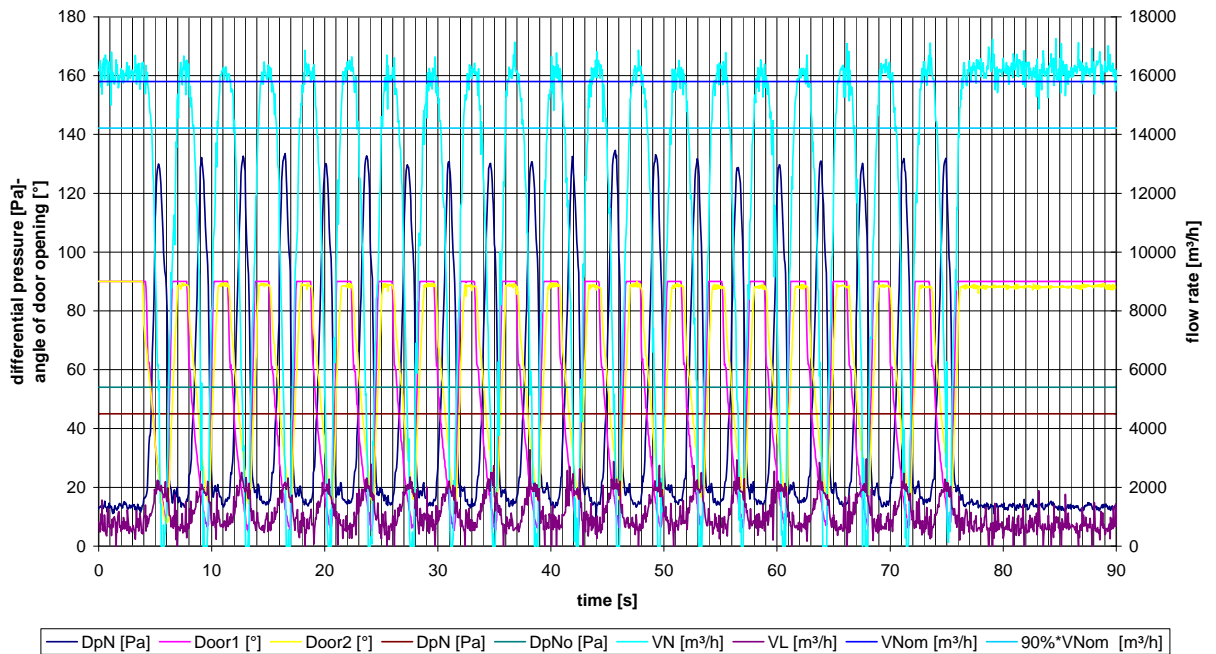

Report Nr. DDS10-02-1 (Annex C)
 SMAY – iSWAY-FC®
 - Test Drawings -

DDS10-02-12 - SMAY Sp. z o.o. - iSWAY-FC®
Resonance Test - t1=1s - t3=2s - Performance class 1

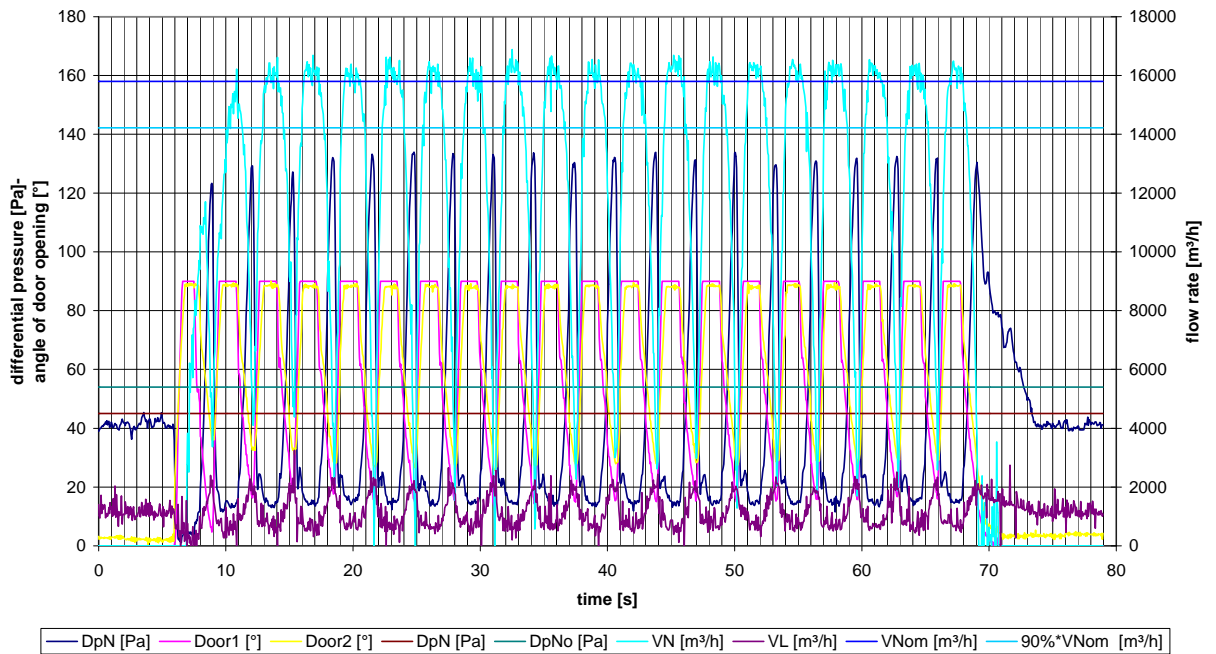

DDS10-02-13 - SMAY Sp. z o.o. - iSWAY-FC®
Resonance Test - t1=1s - t3=2s - Performance class 1

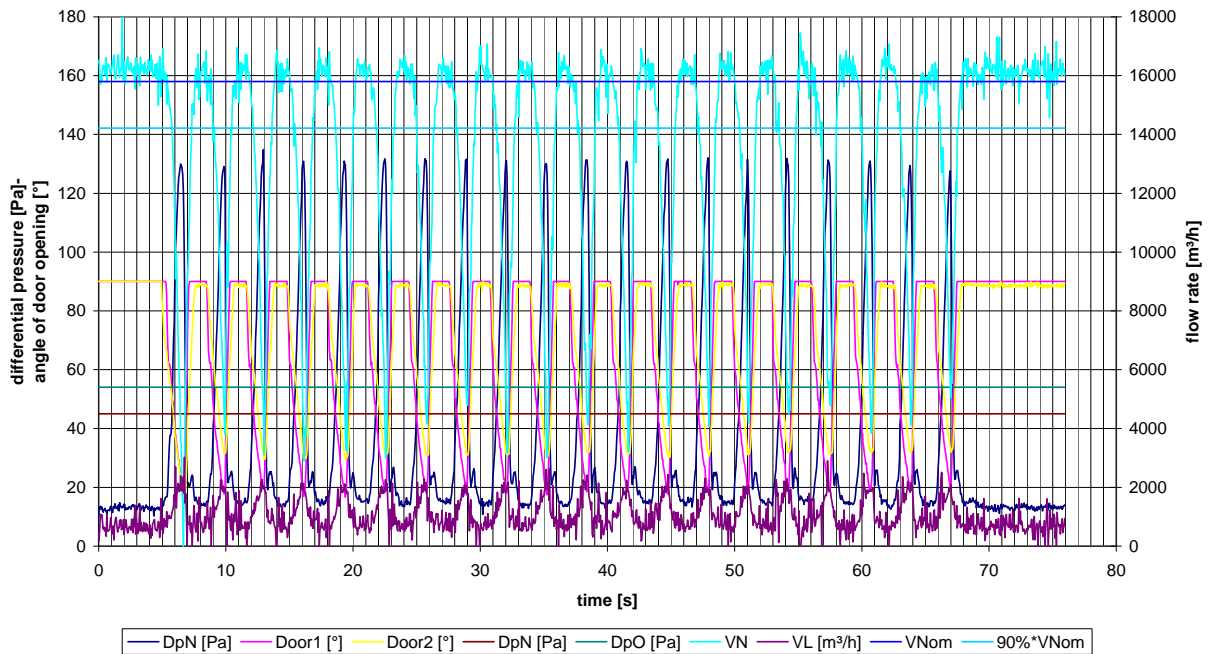

Report Nr. DDS10-02-1 (Annex C)
SMAY – iSWAY-FC®
- Test Drawings -

DDS10-02-14 - SMAY Sp. z o.o. - iSWAY-FC®
 Resonance Test - t1=1s - t3=1,5s - Performance class 1

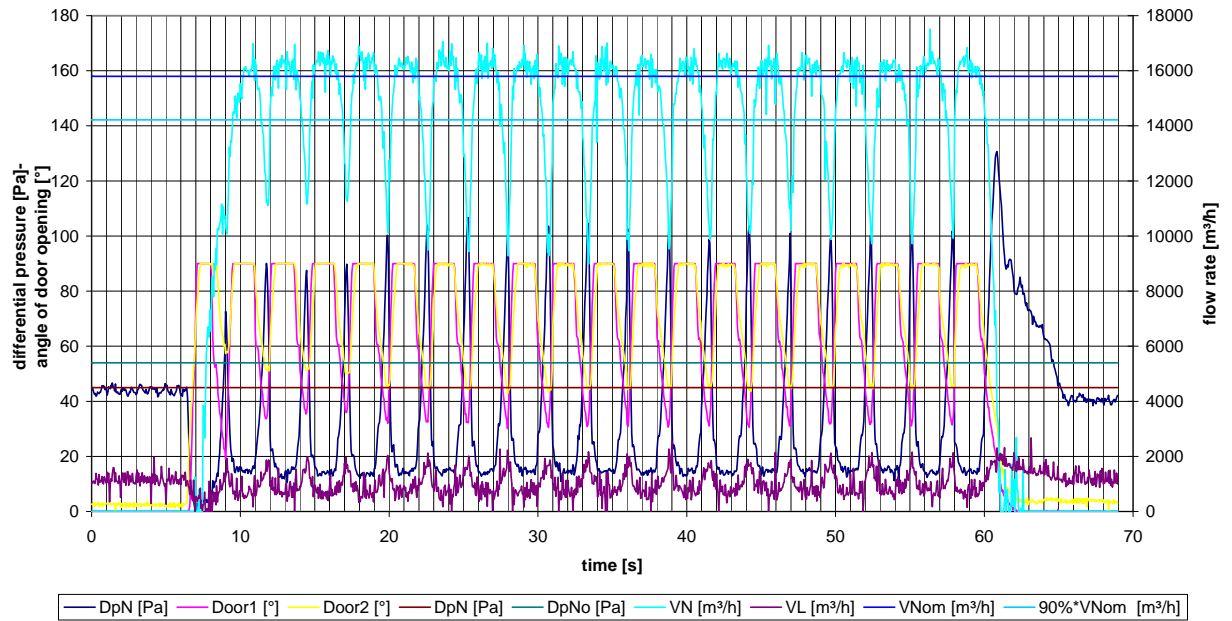

DDS10-02-15 - SMAY Sp. z o.o. - iSWAY-FC®
 Resonance Test - t1=1s - t3=1,5s - Performance class 1

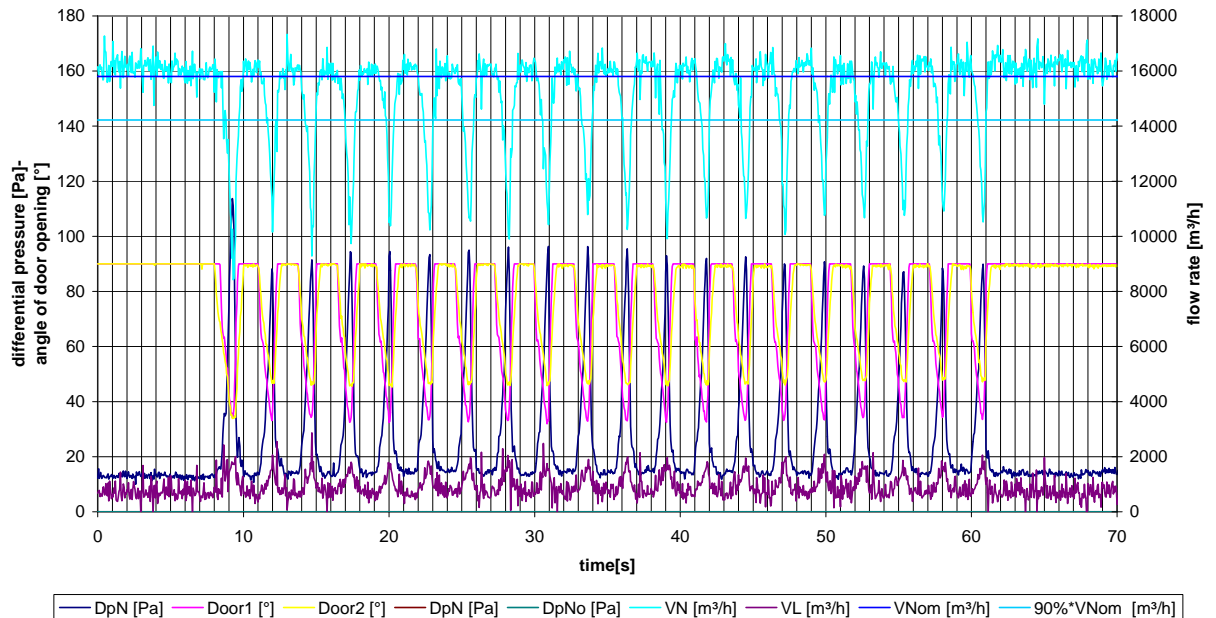

Report Nr. DDS10-02-1 (Annex C)
 SMAY – iSWAY-FC®
 - Test Drawings -

DDS10-02-16 - SMAY Sp. z o.o. - iSWAY-FC®
Resonance Test - t1=1s - t3=1s - Performance class 1

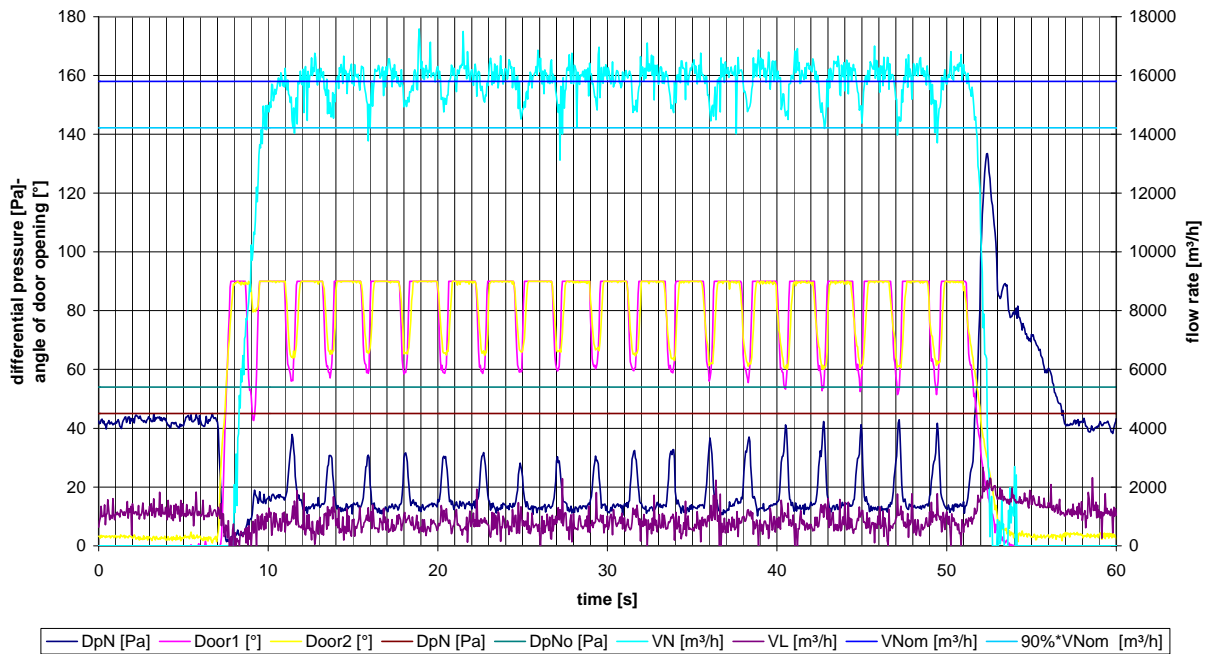

DDS10-02-17 - SMAY Sp. z o.o. - iSWAY-FC®
Resonance Test - t1=1s - t3=1s - Performance class 1

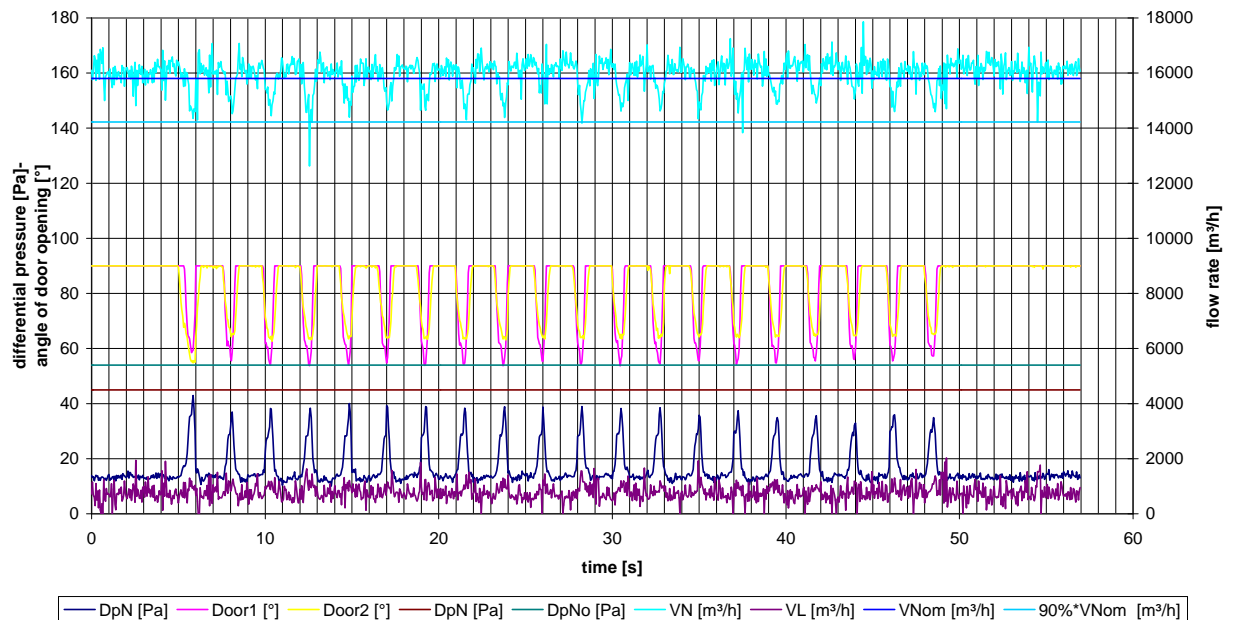

Report Nr. DDS10-02-1 (Annex C)
SMAY – iSWAY-FC®
- Test Drawings -

Performance Class 2 – Functionality

DDS10-02-03 - SMAY Sp. z o.o. - iSWAY-FC®
Functionality - Performance class 2

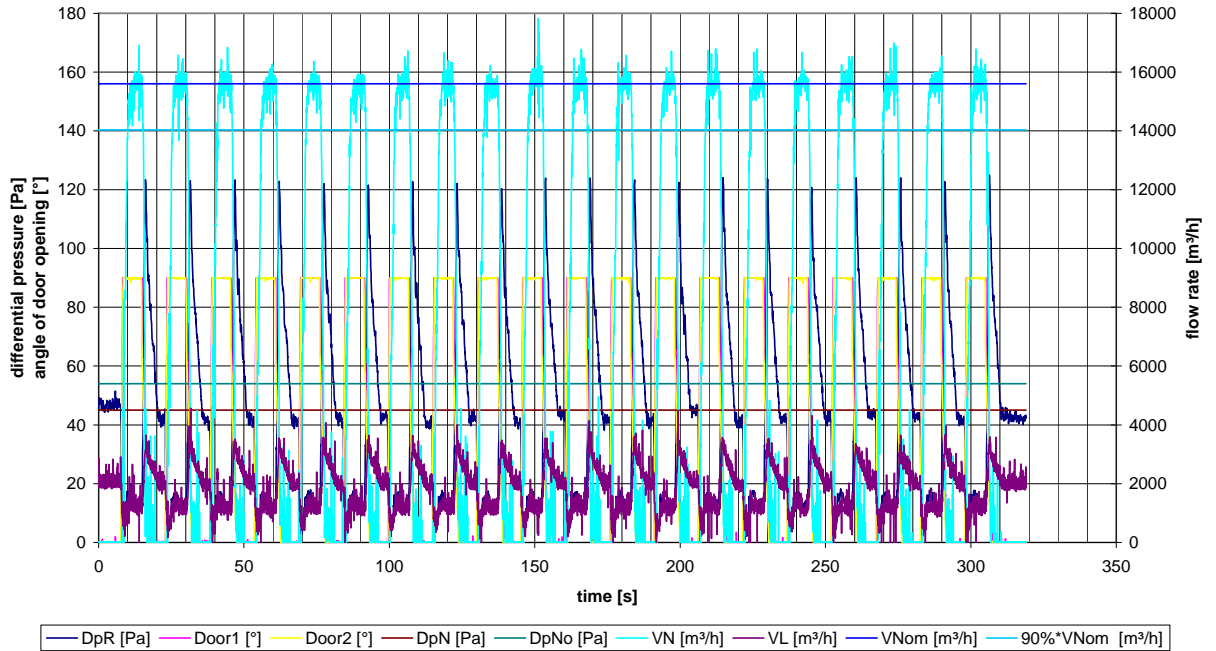

Performance Class 2 – Durability

DDS10-02-29 - SMAY Sp. z o.o. - iSWAY-FC®
Durability - Performance class 2

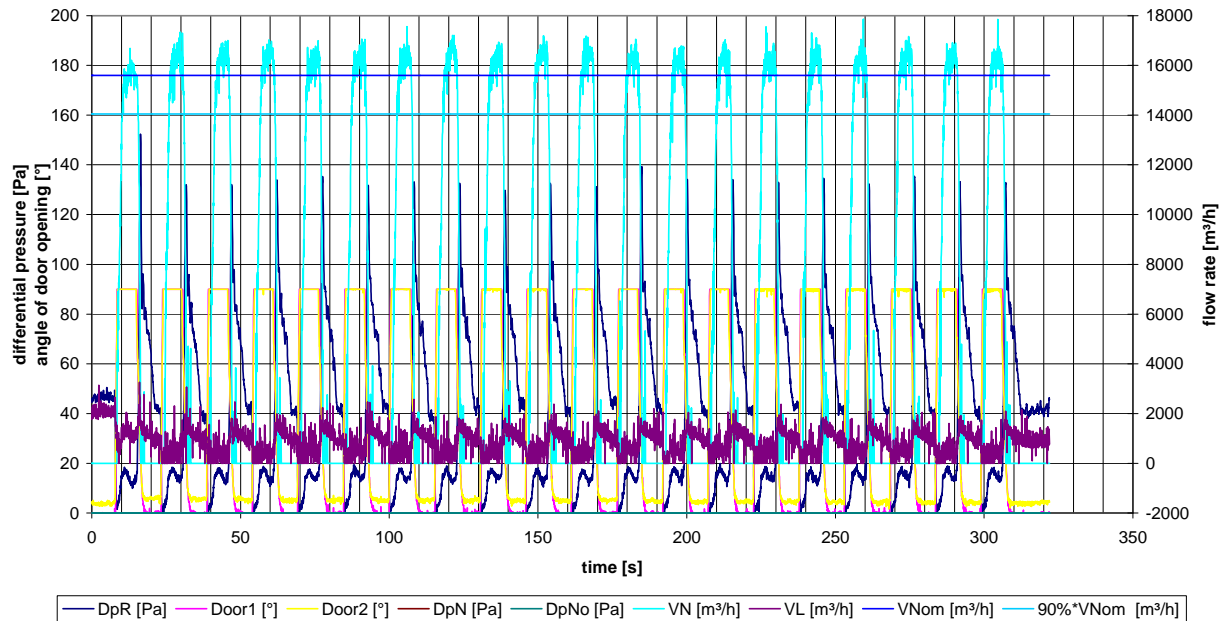

Report Nr. DDS10-02-1 (Annex C)
SMAY – iSWAY-FC®
- Test Drawings -

Performance Class 2 – Resonance test

DDS10-02-30 - SMAY Sp. z o.o. - iSWAY-FC®
 Resonance Test - t1 = 1s - t3 = 3s - Performance class 2

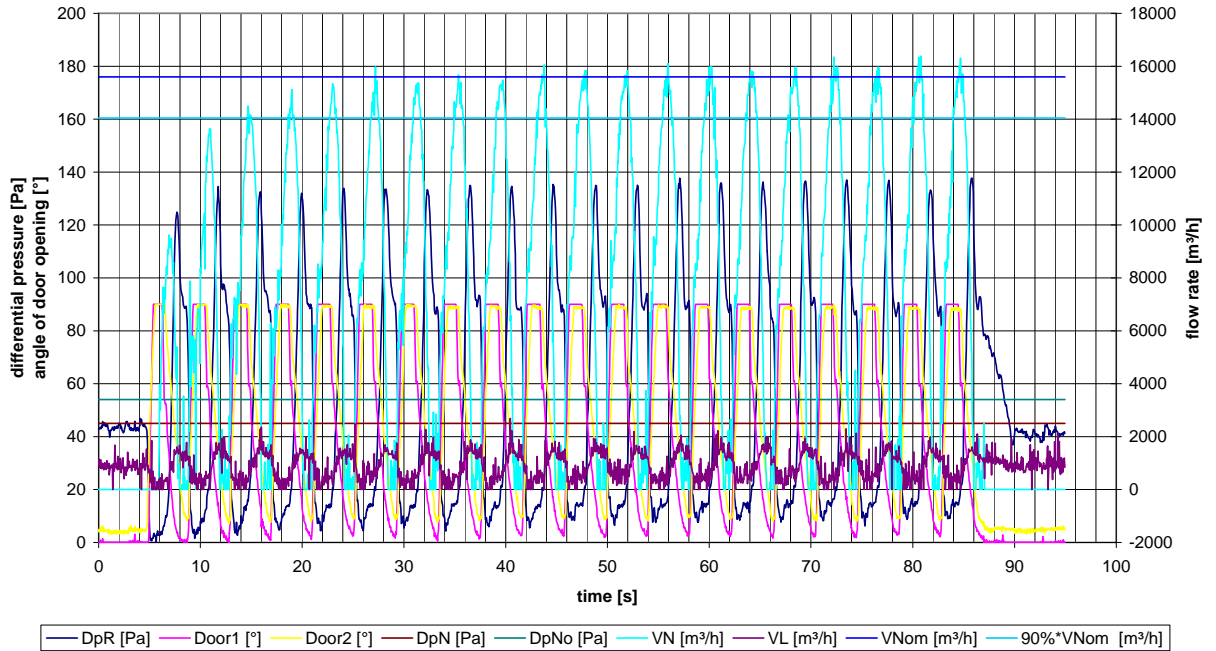

DDS10-02-31 - SMAY Sp. z o.o. - iSWAY-FC®
 Resonance Test - t1 = 1s - t3 = 3s - Performance class 2

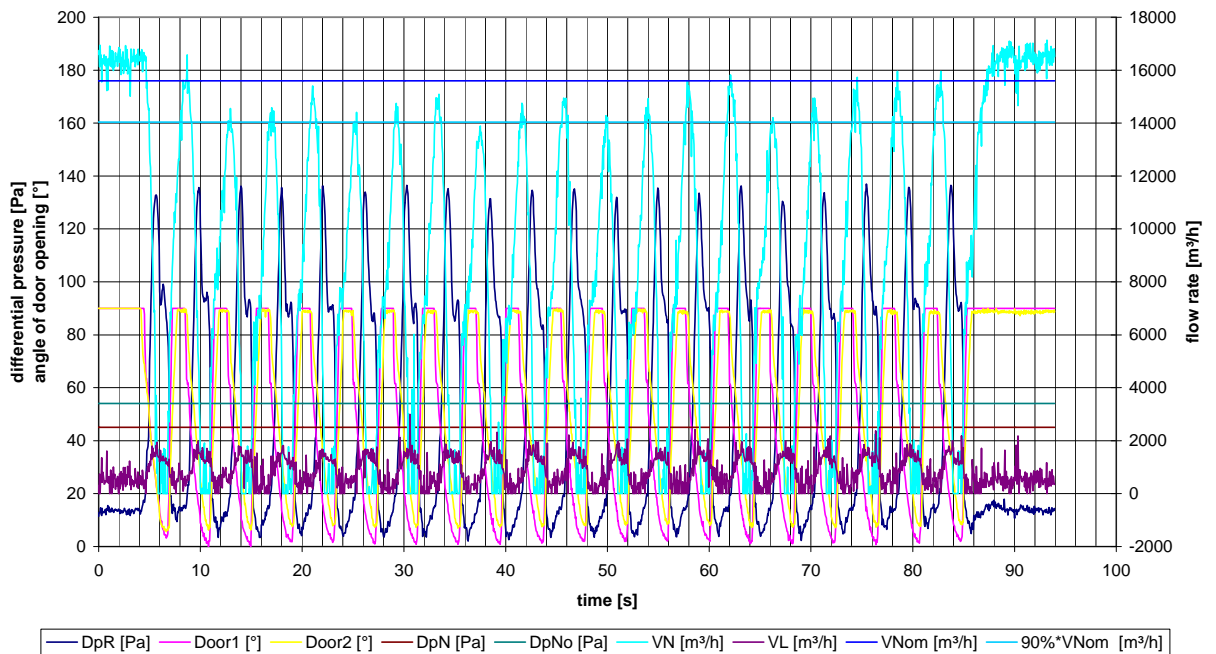

Report Nr. DDS10-02-1 (Annex C)
 SMAY – iSWAY-FC®
 - Test Drawings -

DDS10-02-31 - SMAY Sp. z o.o. - iSWAY-FC®
 Resonance Test - t1 = 1s - t3 = 2,5s - Performance class 2

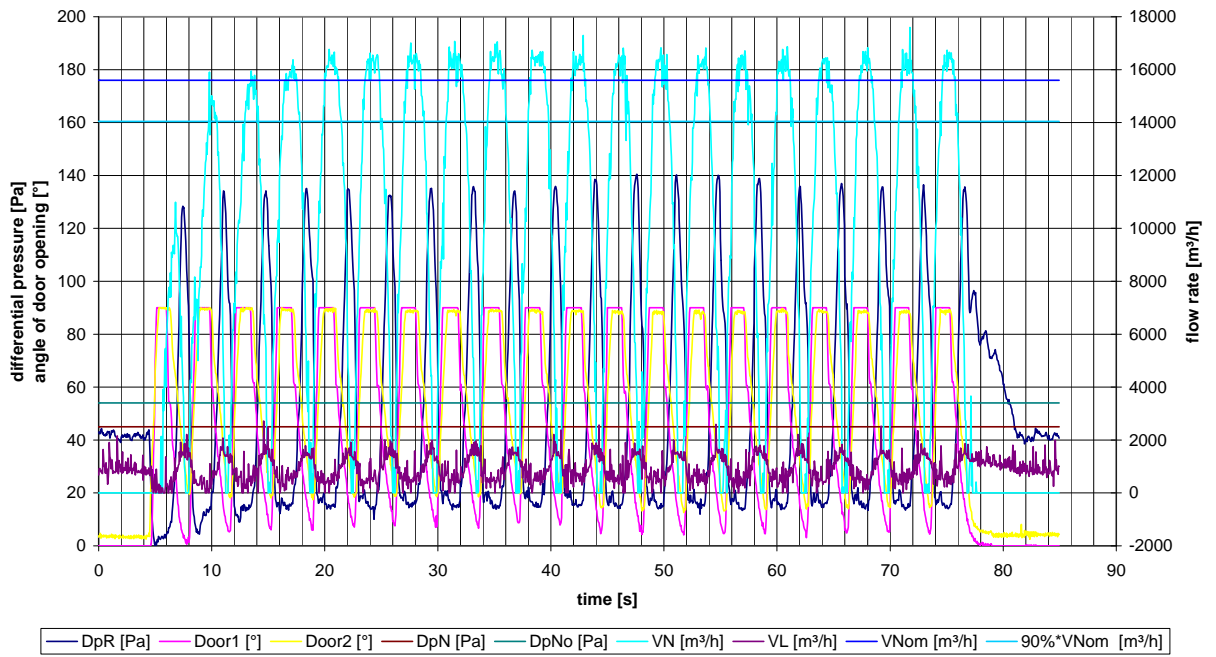

DDS10-02-33 - SMAY Sp. z o.o. - iSWAY-FC®
 Resonance Test - t1 = 1s - t3 = 2,5s - Performance class 2

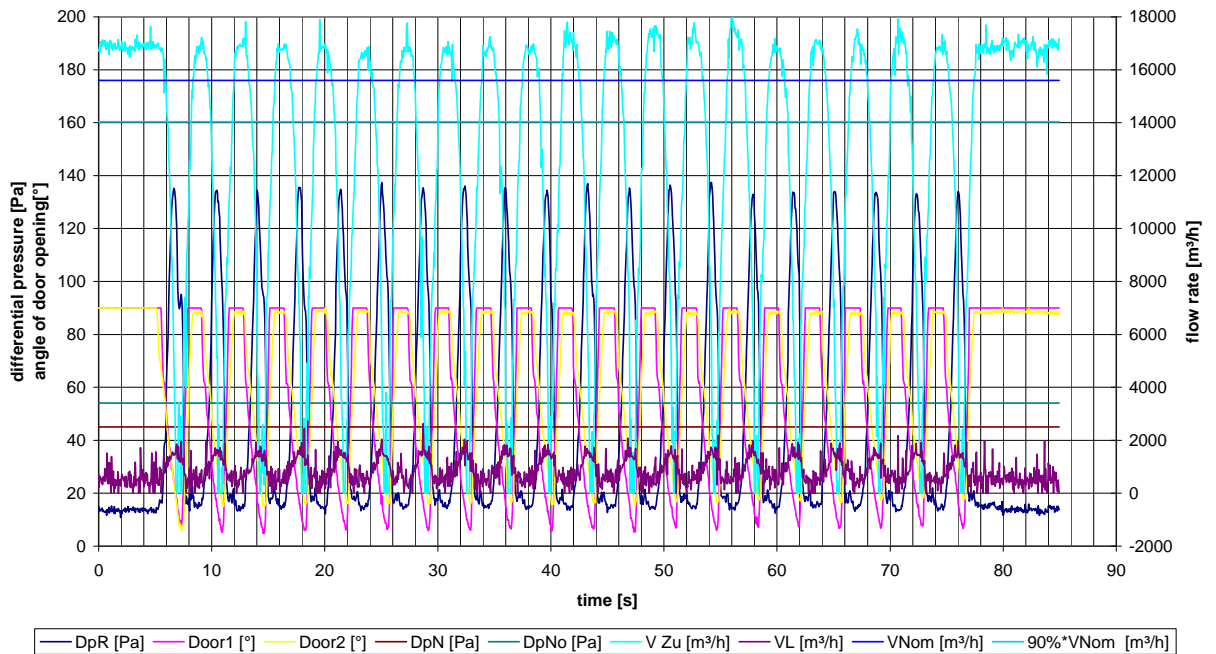

Report Nr. DDS10-02-1 (Annex C)
 SMAY – iSWAY-FC®
 - Test Drawings -

DDS10-02-34 - SMAY Sp. z o.o. - iSWAY-FC®
 Resonance Test - t1 = 1s - t3 = 2s - Performance class 2

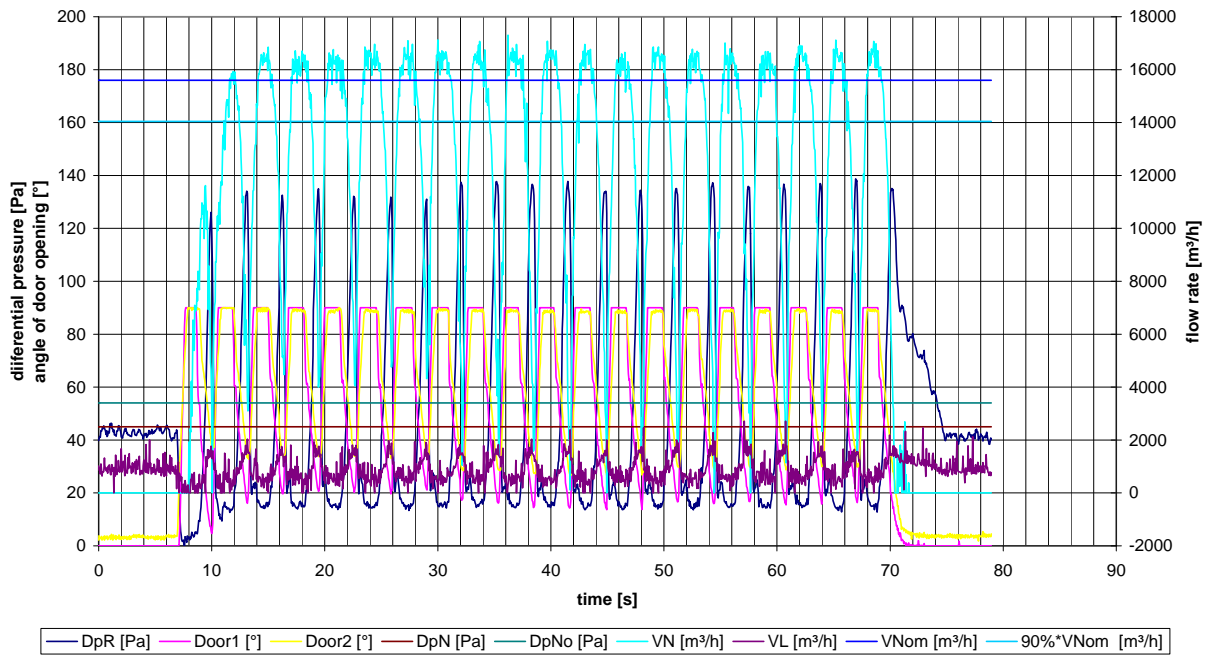

DDS10-02-35 - SMAY Sp. z o.o. - iSWAY-FC®
 Resonance Test - t1 = 1s - t3 = 2s - Performance class 2

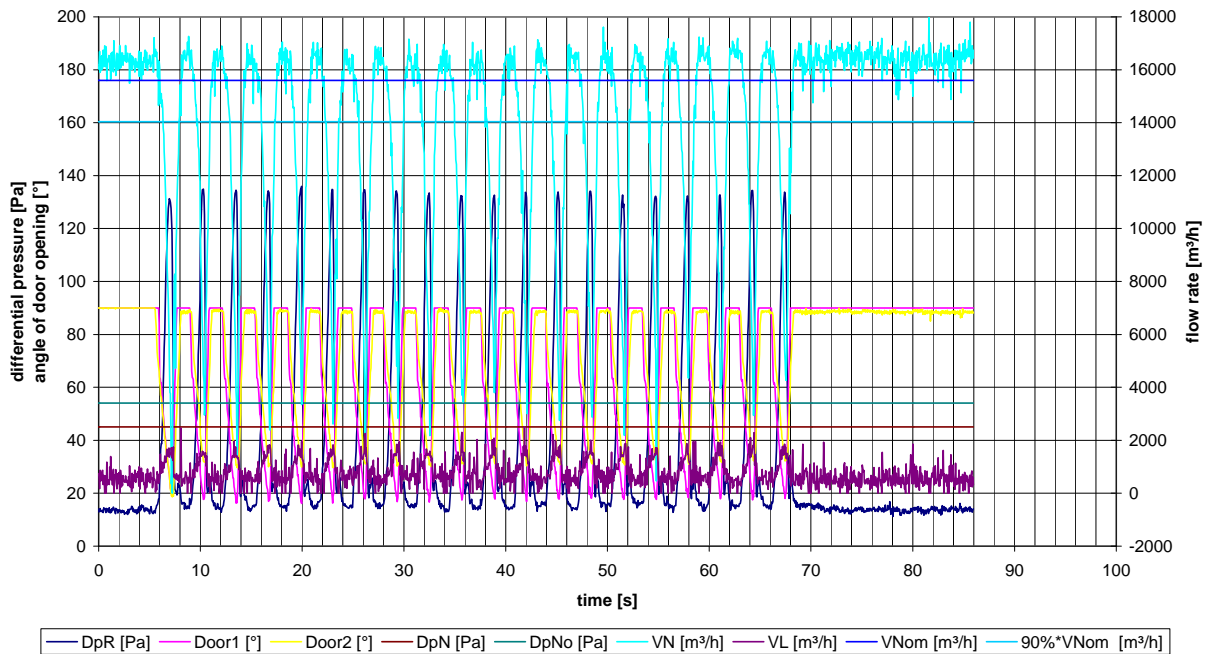

Report Nr. DDS10-02-1 (Annex C)
 SMAY – iSWAY-FC®
 - Test Drawings -

DDS10-02-36 - SMAY Sp. z o.o. - iSWAY-FC®
 Resonance Test - t1 = 1s - t3 = 1,5s - Performance class 2

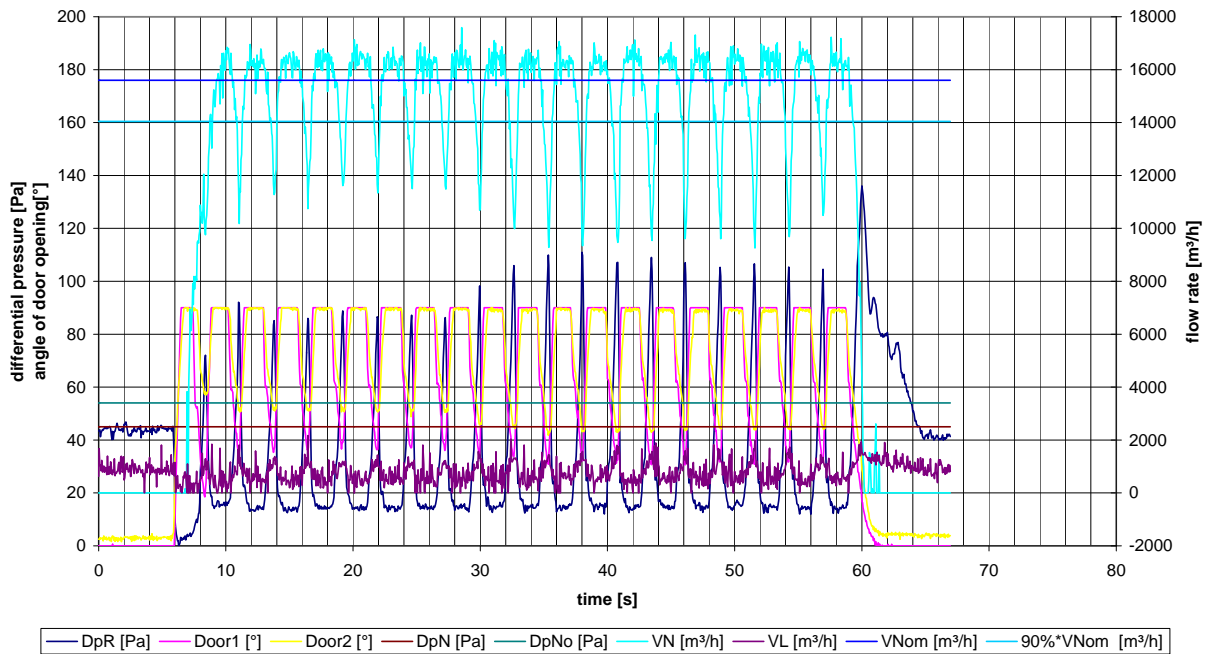

DDS10-02-37 - SMAY Sp. z o.o. - iSWAY-FC®
 Resonance Test - t1 = 1s - t3 = 1,5s - Performance class 2

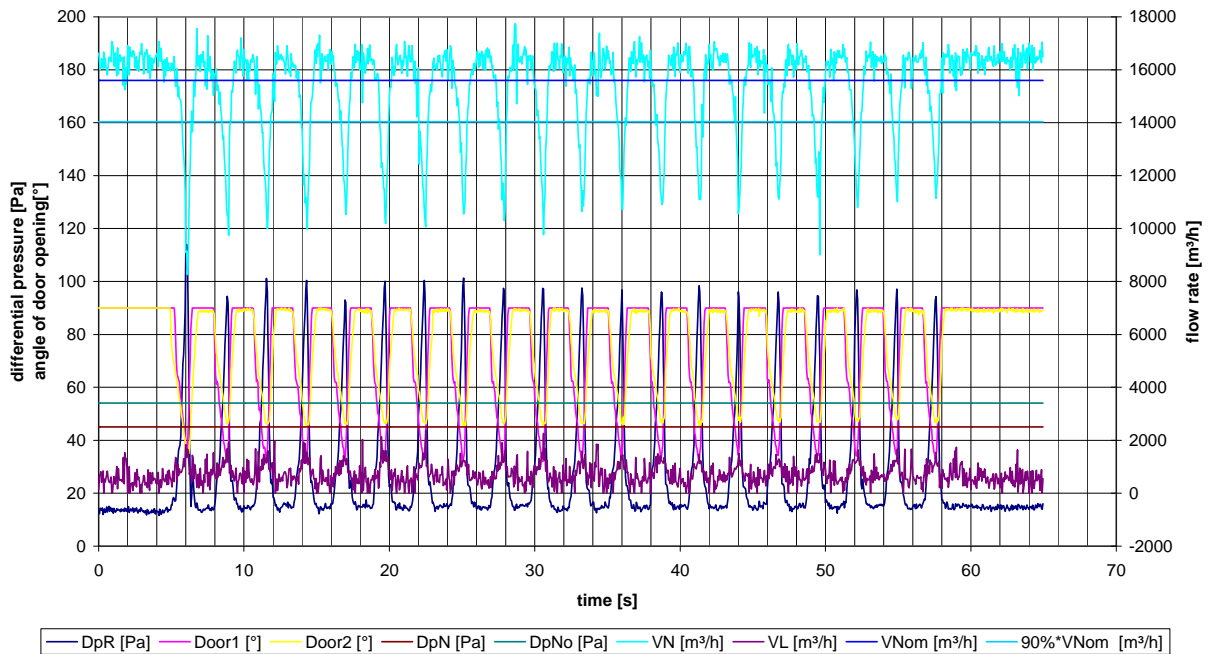

Report Nr. DDS10-02-1 (Annex C)
 SMAY – iSWAY-FC®
 - Test Drawings -

DDS10-02-38 - SMAY Sp. z o.o. - iSWAY-FC®
 Resonance Test - t1 = 1s - t3 = 1s - Performance class 2

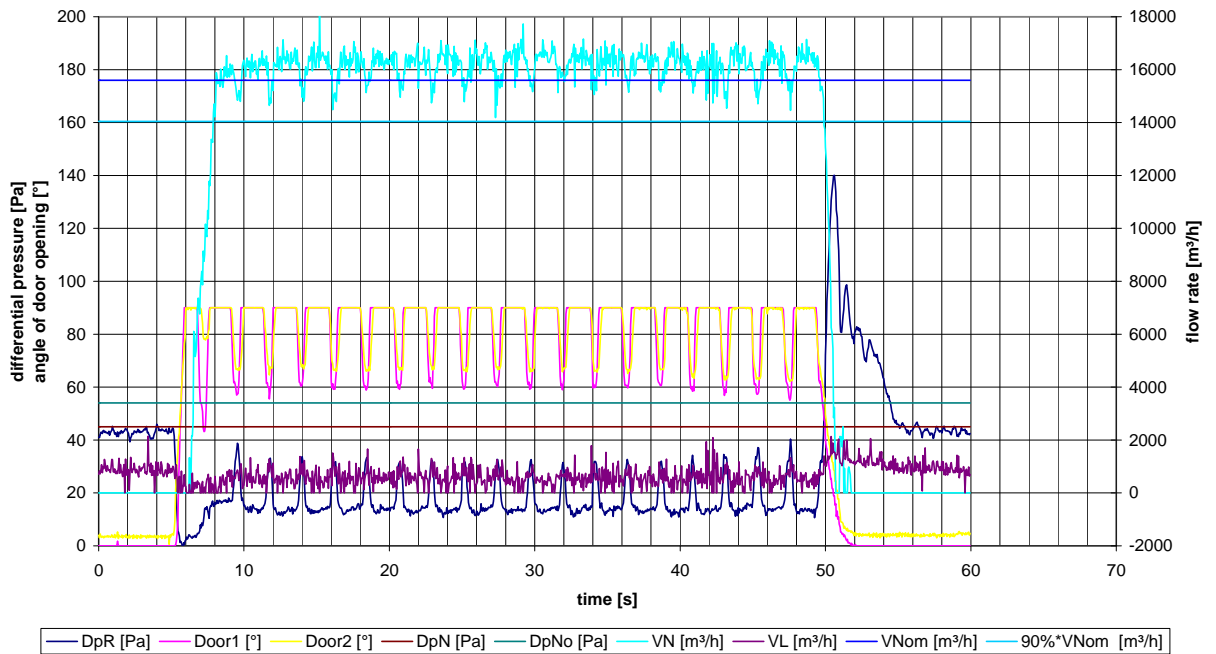

DDS10-02-39 - SMAY Sp. z o.o. - iSWAY-FC®
 Resonance Test - t1 = 1s - t3 = 1s - Performance class 2

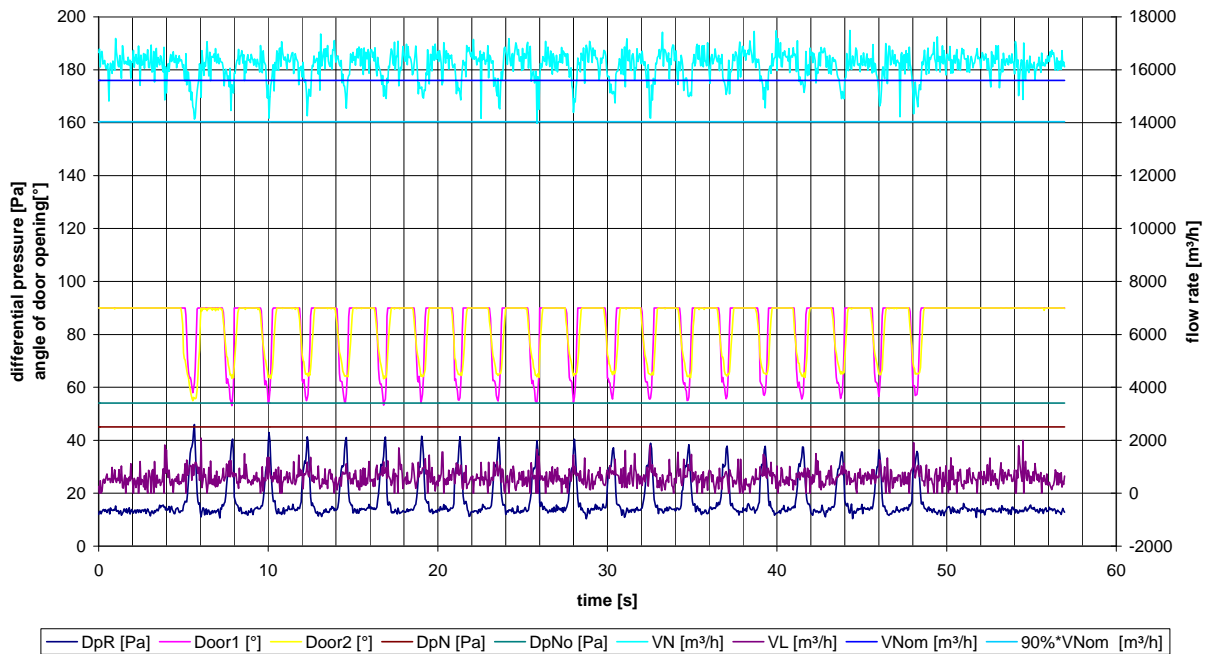

Report Nr. DDS10-02-1 (Annex C)
 SMAY – iSWAY-FC®
 - Test Drawings -