

Technical brochure

CCMT - Electrically operated valves for transcritical and subcritical CO₂



The CCMT is an electrically operated valve designed specifically for operation in CO₂ systems.

The valve is capable of functioning either as an expansion valve, as a pressure regulator for the gascooler or as a gas bypass valve with back-pressure regulation in transcritical or subcritical applications.

Features

- Designed for high pressure CO₂ systems with maximum working pressure of 140 bar / 2030 psig.
Applicable to other common refrigerants as well. The CCMT is not applicable for flammable refrigerants and Ammonia.
The CCMT is compatible with the oil types PAG, POE and PVE
- Regulating cone ensures optimum regulating accuracy, particularly at part load.
- Patented cone and balance design
- The PEEK seat provides excellent valve tightness and robustness.
- Combined butt weld and solder connections
- Top part with built-in strainer
- MOPD up to 90 bar (1305 psi)
- Standard M12 connector for simple and flexible connection to the motor driver.
- For manual operation and service of the CCMT an AST-g service driver is available.
For further information please contact your local Danfoss sales office.
- Low weight and compact design.
- Easy to service. Insert easily taken out by removing top part.

Technical data

Parameter	CCMT
Compatibility	R744
MOPD	90 bar (1305 psi)
Max. working pressure (PS/MWP)	140 bar (2030 psi)
Refrigerant temperature range	-40°C to 60°C (-40°F to 140°F)
Ambient temperature	-40°C to 60°C (-40°F to 140°F)
Total stroke	4.8 mm (0.2 in.)
Motor enclosure	IP 67

CCMT - Electrically operated valves for transcritical and subcritical CO₂

Electrical data

Parameter	CCMT
Stepper motor type	Bi-polar - permanent magnet
Step mode	2 phase full step
Phase resistance	52Ω ±10%
Phase inductance	85 mH
Holding current	Depends on application. Full current allowed (100% duty cycle)
Step angle	7.5° (motor), 0.9° (lead screw), Gearing ration 8.5:1. (38/13):1
Nominal voltage	(Constant voltage drive) 12 V dc -4% +15%, 150 steps/sec.
Phase current	(Using chopper drive) 100 mA RMS -4% +15%,
Max. total power	Voltage / current drive: 5.5 / 1.3 W (UL: NEC class 2)
Step rate	max. 150 steps/sec. (constant voltage drive) max. 300 steps/sec. (chopper current drive)
Total steps	CCMT 2, 4 & 8: 1100 [+80 / - 0] steps
Full travel time	CCMT 2, 4 & 8: 5 sec. at 220 steps/sec.
Reference position	Overdriving against the full close position
Electrical connection	4 wire 0.5 mm ² (0.02 in ²), 0.3 m (1 ft) long cable

Stepper motor switch sequence:			
CCMT	Connector		
	4	Black	4
	3	White	3
	2	Green	2
	1	Red	1
	Connection 1	Wire Colour	Connection 2
	Pin Out		

Stepper motor switch sequence:

	STEP	Coil I		Coil II		
		Red	Green	White	Black	
↑ CLOSING ↑	1	+	-	+	-	↓ OPENING ↓
	2	+	-	-	+	
	3	-	+	-	+	
	4	-	+	+	-	
	1	+	-	+	-	

Design

Approvals

The CCMT valve concept is designed to fulfil global refrigeration requirements.

For specific approval information, please contact your local Danfoss sales office.

The CCMT valves are compliant with the European Pressure Equipment Directive.

For further details / restrictions - see Installation Instruction.

Valve body and top cover material:
Stainless steel

CCMT valves	
Classified for	Fluid group I
Category	Article 3, paragraph 3

Design
(Continued)

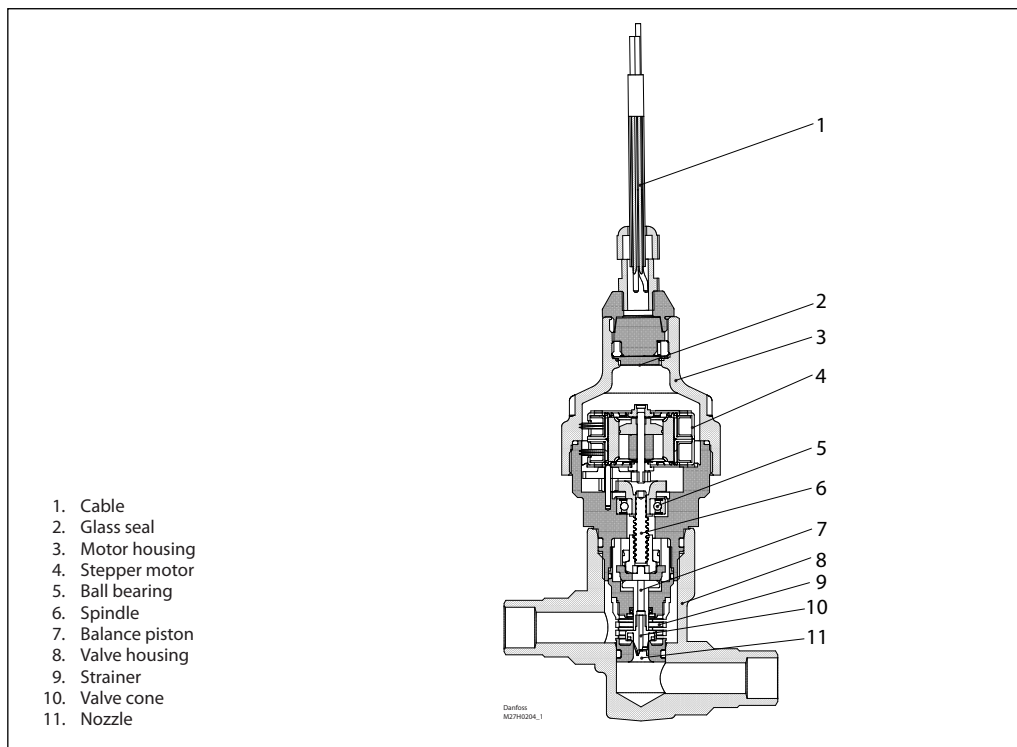

Valve operation

The CCMT valve is developed for transcritical CO₂ applications. The CCMT valve can be used in systems with flash gas bypass, parallel compression as well as in stand-alone applications.

The CCMT valve can be used in transcritical and subcritical conditions.

The most typical application is with flash gas bypass.

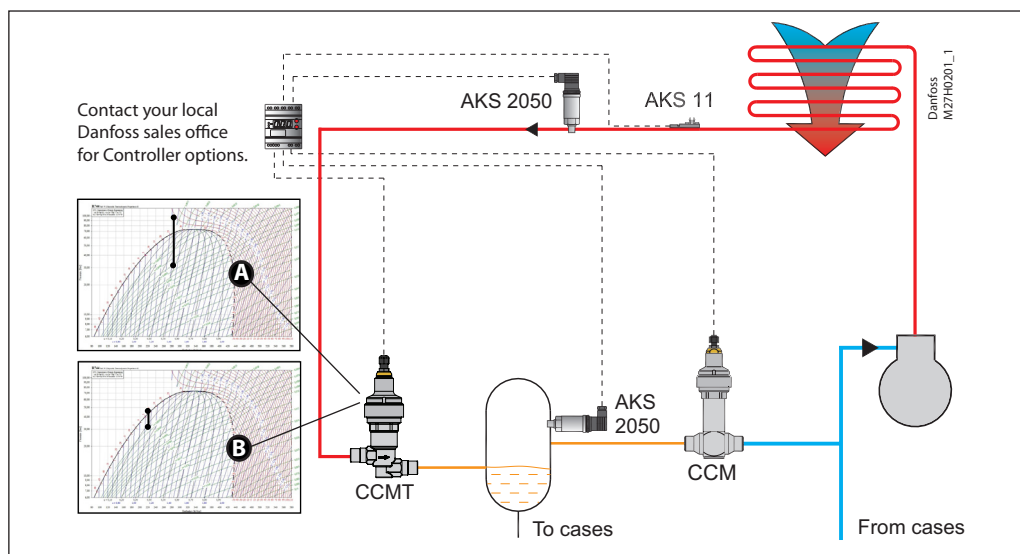

Application 1

Pressure optimization is performed by the CCMT valve, which is installed at the outlet of the gas cooler (see the figure above) and a matching Danfoss controller. This design provides the possibility to optimize gas cooler pressure and intermediate receiver pressure independently.

The pressure in the receiver is one important parameter, but the design of the receiver is also important. It typically acts as a liquid separator as well.

In order to keep the intermediate pressure low, flash gas is expelled through a gas bypass valve to the suction side of the compressor.

The two phase mixture from the CCMT valve has to be separated before gas enters the gas bypass. For larger systems the gas bypass valve must be of type CCM.

Please refer to the www.danfoss.com/CO2 for more information on CO₂ systems.

Valve operation
(Continued)

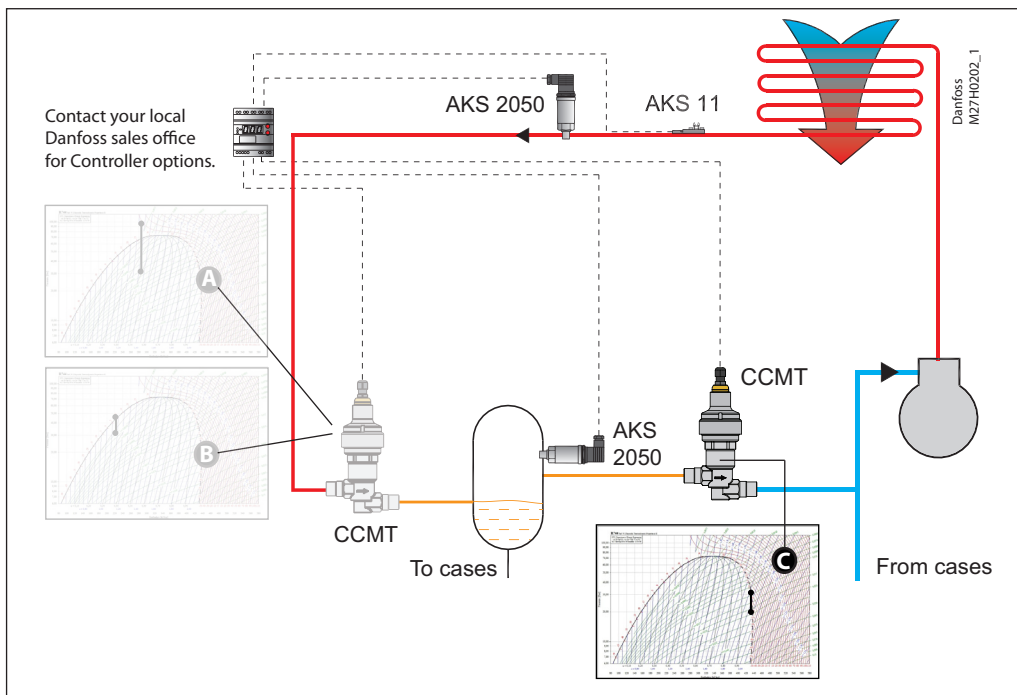

Application 2

Pressure optimization is performed by the CCMT valve which is installed at the outlet of the gas cooler (see the figure above) and a matching Danfoss controller. This design provides the possibility to optimize gas cooler pressure and intermediate receiver pressure independently.

The pressure in the receiver is one important parameter, but the design of the receiver is also important. It typically acts as a liquid separator as well.

In order to keep the intermediate pressure low, flash gas is expelled through a gas bypass valve to the suction side of the compressor. The two phase mixture from the CCMT valve has to be separated before gas enters the gas bypass.

For smaller systems the gas bypass valve can be a CCMT as well.

Please refer to the www.danfoss.com/CO2 for more information on CO₂ systems.

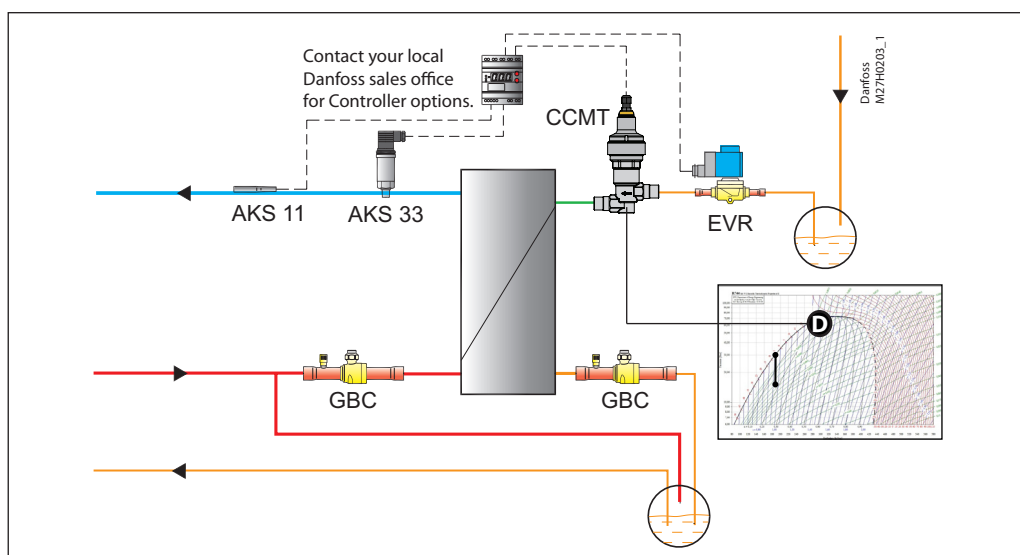

Application 3

A liquid expansion valve is typically used for injection in plate heat exchangers of CO₂/CO₂ cascades, or as an expansion valve for CO₂ evaporators. For the liquid injection applications CCMT is used with a matching Danfoss controller.

Please refer to the www.danfoss.com/CO2 for more information on CO₂ systems.

Valve operation
(Continued)

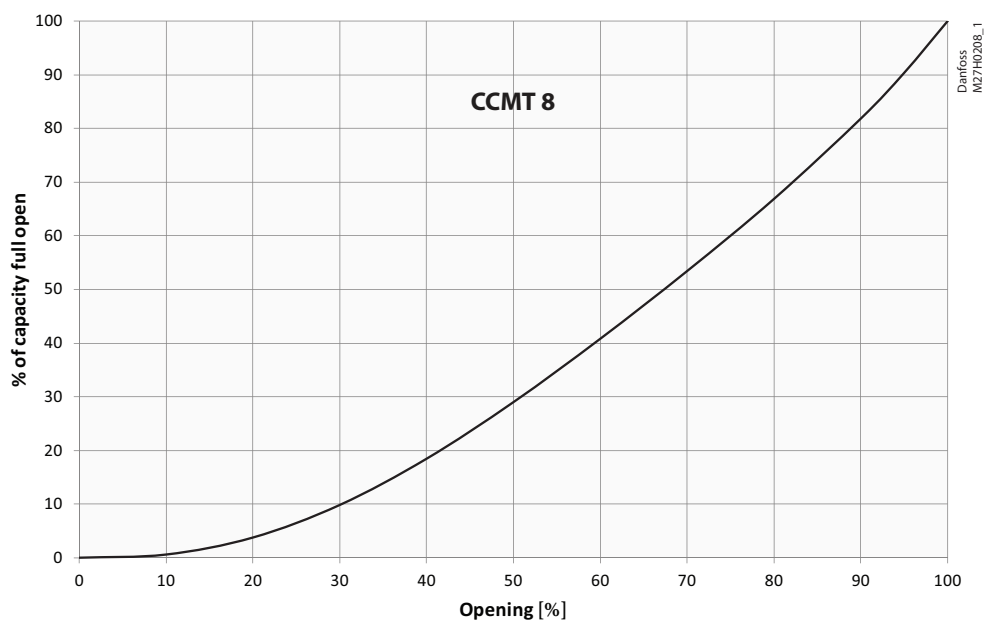
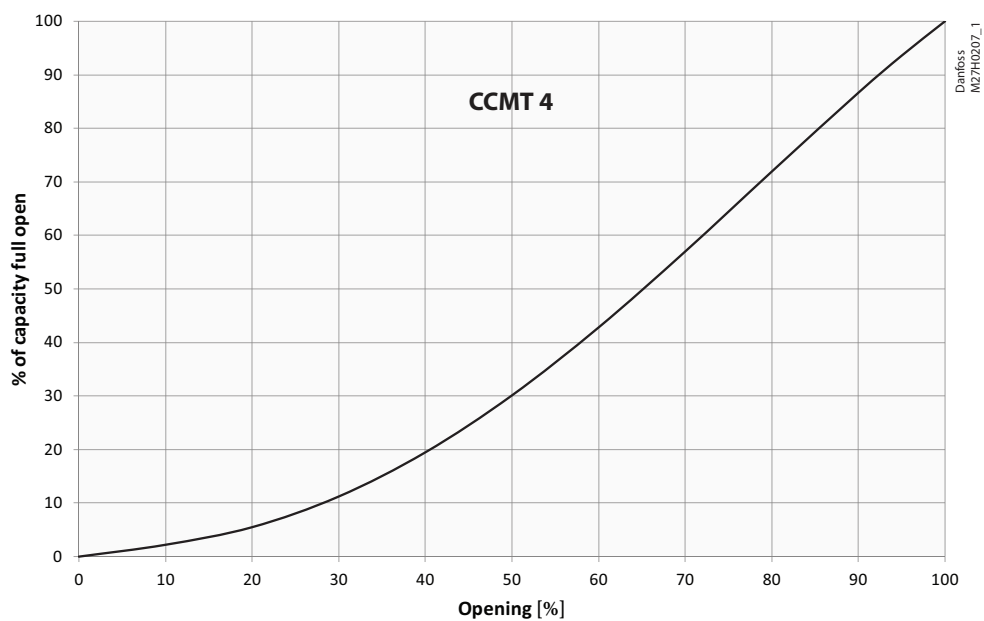
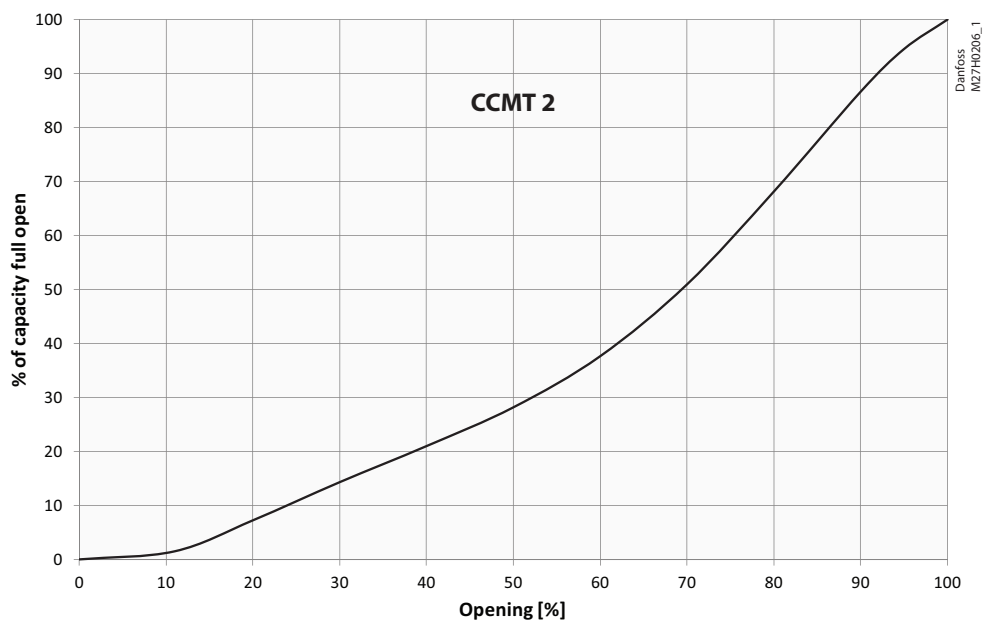

CCMT - Electrically operated valves for transcritical and subcritical CO₂

CCMT capacities

Determination of valves working in the transcritical area (application 1, **A**) is complex and normally done by experimental trials.

Experience show that in many cases a valve selected for the subcritical area (application 1, **B**) will match the transcritical conditions as well, and thus be able to cover the full range.

It is recommended to use below tables as indicators for the initial valve selection.

Below figures are valid for the pressure optimized systems mentioned above, controlled by a Danfoss controller (ex. EKC 326A) with a "minimum pressure gas cooler" setting and a constant receiver pressure.

The figures indicate the maximum evaporator cooling capacity in kW given by the valve.

CCMT as high pressure valve (application 1, **B**) – evaporator capacity

	45 bar min pressure gas cooler 30 bar receiver pressure	45 bar min pressure gas cooler 37 bar receiver pressure	50 bar min pressure gas cooler 37 bar receiver pressure
CCMT 2	24 kW	18 kW	21 kW
CCMT 4	65 kW	48 kW	56 kW
CCMT 8	130 kW	97 kW	112 kW

CCMT as low pressure Liquid Expansion valve (application 3, **D**) – evaporator capacity

	Inlet temp +2 °C (saturated) Outlet temp -10 °C	Inlet temp +2 °C (saturated) Outlet temp -30 °C	Inlet temp -5 °C (saturated) Outlet temp -10 °C	Inlet temp -5 °C (saturated) Outlet temp -30 °C
CCMT 2	24 kW	38 kW	16 kW	34 kW
CCMT 4	65 kW	100 kW	45 kW	90 kW
CCMT 8	130 kW	185 kW	90 kW	172 kW

Superheat 10 K, Subcooling 0K

Example

If your system settings are:

Minimum gas cooler pressure	45 bar
Receiver pressure	37 bar
Inlet temp liquid expansion valve	+2°C (37 bar)
Outlet temp (T _{evaporator})	-30°C

and you need an evaporator cooling capacity of 70 kW:

The right selection is:

High pressure valve (application 1, **B**): CCMT8 (97 kW max)

Liquid expansion valve (application 3, **D**): CCMT4 (100 kW max)

For selection of by-pass valve (application 2, **C**) please contact your local Danfoss sales office.

CCMT - Electrically operated valves for transcritical and subcritical CO₂

Ordering

Valve incl. actuator

Type	Connections (Combi)		k _v value	Code number
	Weld ¹⁾ [in]	Solder ODF x ODF [in]		
CCMT 2	1/2 x 1/2	5/8 x 5/8	0.17	027H7200
CCMT 4			0.45	027H7201
CCMT 8			0.8	027H7202

¹⁾ OD according to EN 10220

Accessories:

Cable with M12 connector - 5 meter (16.4 ft.), code no. **034G2323**

EKD 316 - converter box, code no. **084B8040**

EKA 164A - Display, code no. **084B8563**

AKA 211 - Cable filter, code no. **084B2238**

AST-G - Manual driver box, code no. **034G0013**

Dimension and weight for CCMT

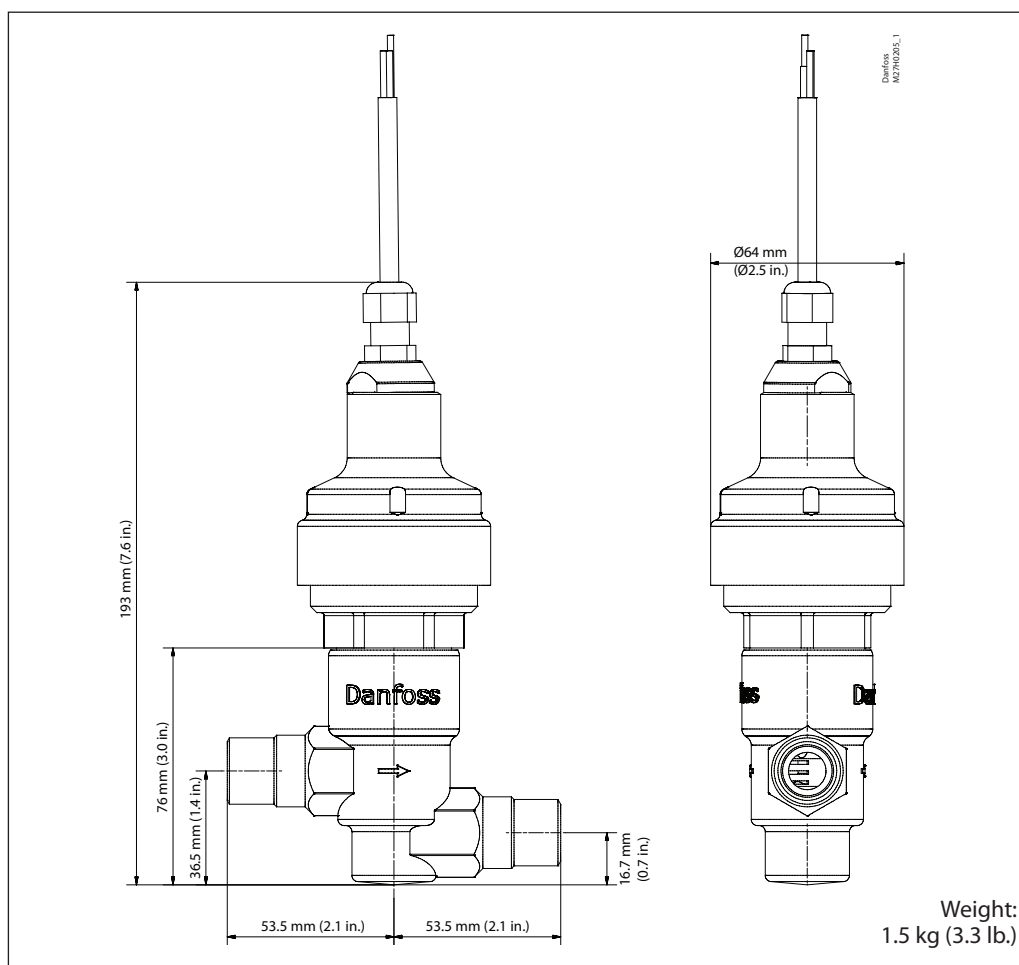

For further information please contact your local Danfoss sales office.

